

## FERLUX GALAXY

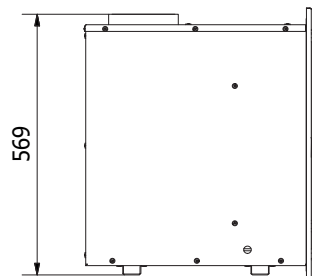

[Ver más información online](#)

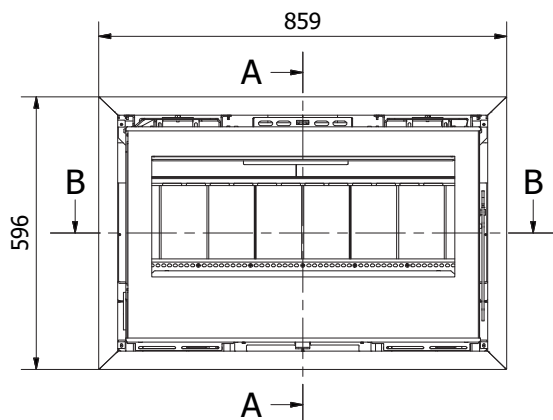

A-A

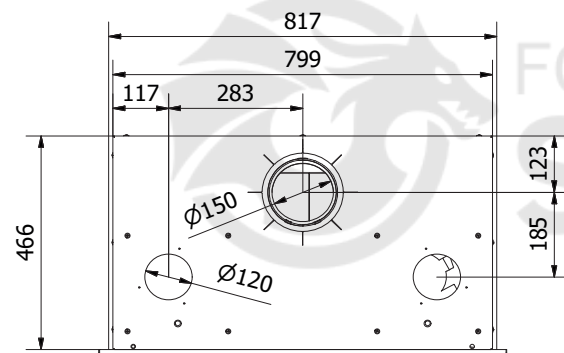
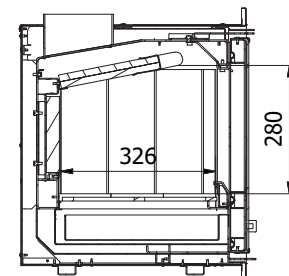

B-B

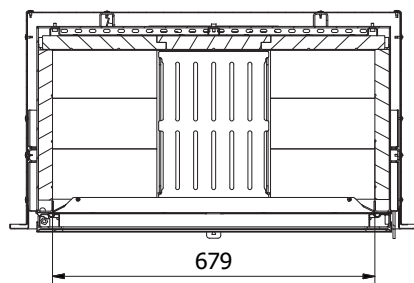

CHIMENEAS Y BARBACOAS FERLUX, S.A.  
 POLIG. INDUST. EL POLEAR, PARC. 1  
 29313 VILLANUEVA DEL TRABUCO MALAGA (ESPAÑA)  
 TEL. +34 952 03 11 17 FAX +34 952 03 11 18

## Datos técnicos

POTENCIA TÉRMICA NOMINAL	12,1 Kw
RENDIMIENTO	80,5 %
VOLUMEN CALEFACTABLE	314 M <sup>3</sup>
EMISIONES CO (13% DE O <sub>2</sub> )	0,120 %
PARTICULADO (13% DE O <sub>2</sub> )	30,4 MG/NM <sup>3</sup>
OGC (13% DE O <sub>2</sub> )	60,0 MG/NM <sup>3</sup>
NOX (13% DE O <sub>2</sub> )	161,0 MG/NM <sup>3</sup>
TEMPERATURA DE HUMOS	188,8 °C
TIRO MEDIO	10 - 14 PA
CONSUMO	3,33 KG/H
SALIDA DE HUMOS	150 MM
SALIDA DE CANALIZACIÓN	2x120 MM
ENTRADA DE AIRE	N.D.
PESO	111 KG
LONG. MÁX. LEÑA	500 MM
CRISTAL	738x463,5x4 MM

## Requisitos eléctricos

ALIMENTACIÓN	220 - 230 V
FRECUENCIA	50 - 60 Hz
POTENCIA MEDIA ABSORBIDA	48 W