

## FERLUX TEIDE 90

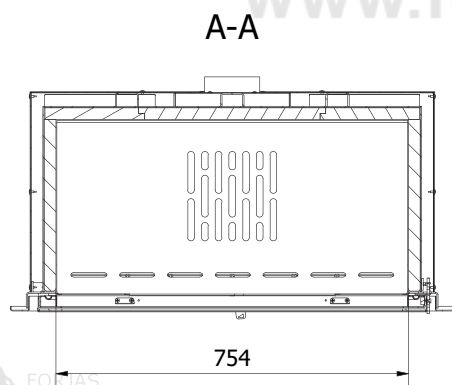

[Ver más información online](#)

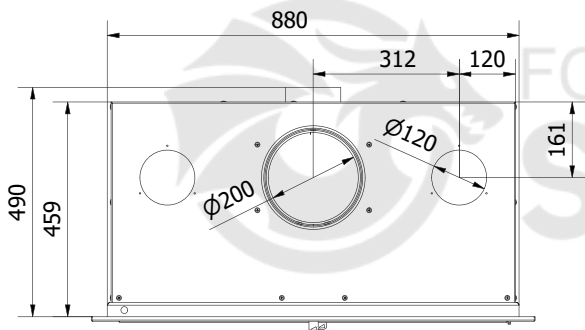
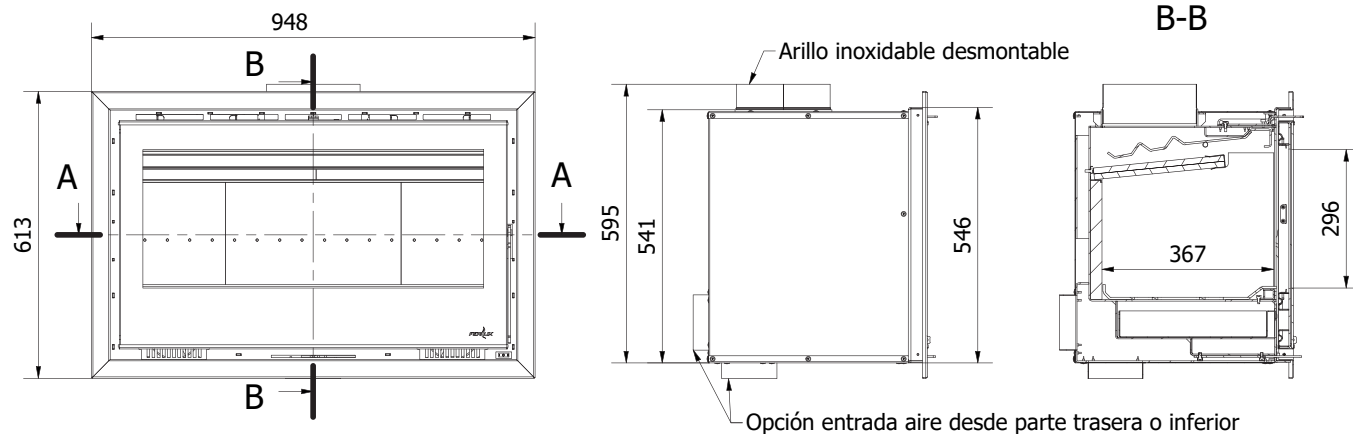

FERLUX | TEIDE 90



CHIMENEAS Y BARBACOAS FERLUX, S.A.  
 POLIG. INDUST. EL POLEAR, PARC. 1  
 29313 VILLANUEVA DEL TRABUCO MALAGA (ESPAÑA)  
 TEL. +34 952 03 11 17 FAX +34 952 03 11 18

## Datos técnicos

POTENCIA TOTAL	11 Kw
POTENCIA TÉRMICA NOMINAL	8,46 Kw
RENDIMIENTO	75 %
VOLUMEN CALEFACTABLE	308 m <sup>3</sup>
EMISIONES CO (13% DE O <sub>2</sub> )	0,08 %
PARTICULADO (13% DE O <sub>2</sub> )	8,0 MG/NM <sup>3</sup>
OGC (13% DE O <sub>2</sub> )	6,0 MG/NM <sup>3</sup>
NOX (13% DE O <sub>2</sub> )	88,0 MG/NM <sup>3</sup>
TEMPERATURA DE HUMOS	272,0 °C
TIRO MEDIO	10 · 14 PA
CONSUMO	2,64 KG/H
SALIDA DE HUMOS	200 MM
SALIDA DE CANALIZACIÓN	2X120 MM
ENTRADA DE AIRE	N.D.
PESO	114 KG
LONG. MÁX. LEÑA	500 MM
CRISTAL	824,5x482,5x4 MM

## Requisitos eléctricos

ALIMENTACIÓN	220 · 230 V
FRECUENCIA	50 · 60 Hz
POTENCIA MEDIA ABSORBIDA	38 W