

## SCAN 84-1

Scan 84-1 fusiona minimalismo y potencia en una estufa de leña compacta. Su diseño depurado y gran cristal frontal realzan el fuego, mientras su tecnología limpia maximiza el calor con mínimo impacto ambiental.



[Ver más información online](#)

UK - DE - FR - IT - ES - NL - SE - NO - DK

## INSTRUCTIONS MANUAL

### MOUNTING OF THE REVOLVING KIT

**UK** · The revolving kit cannot be used on models with heat accumulating stones. **DE** · Der Drehfuß kann nicht auf Modellen mit Wärmespeichersteinen oder mit RLU verwendet werden. **FR** · La base pivotante ne peut pas être utilisée sur les modèles avec pierres accumulante la chaleur. **IT** · Non può essere usato su modelli con pietre refrattarie (per l'accumulo di calore). **ES** · No puede utilizarse en modelos con piedras acumuladoras de calor. **NL** · Kan niet op modellen met warmte accumulerende stenen worden gebruikt. **SE** · Kan inte användas på modeller med värmeakkumulerande stenar. **NO** · Kan ikke brukes på modeller med varmeakkumulerende stein. **DK** · Drejefod kan ikke anvendes på modeller med varmeakkumulerende sten.

Contents of the kit/Das Paket enthält  
De doos bevat/Contenu/La confezione contiene  
Contenido del paquete/Pakken indeholder  
Förpackningen innehåller/Pakken inneholder:

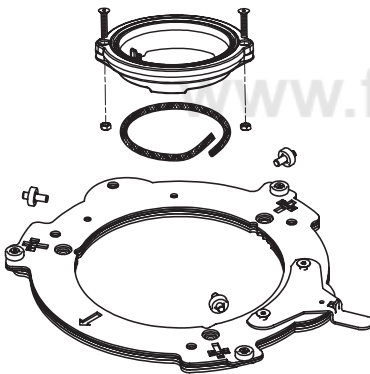

Only to be used  
on Scan 83



FORJAS

SCAN

## 2 UK - MOUNTING OF THE REVOLVING CONNECTING PIECE

www.forjas-salvador.com

www.forjas-salvador.com

1. Remove the top plate.
2. Drill the four holes of the template with an 8 mm drill (A) and remove the residues with a vacuum cleaner.
3. Mount the gasket on the connecting piece. Please keep a distance to the inner side (B).
4. Mount the revolving connecting piece with the screws and nuts.
5. The flue pipe must be provided with a slit fitting the guide pin of the connecting piece (C). If not, a slit must be cut.

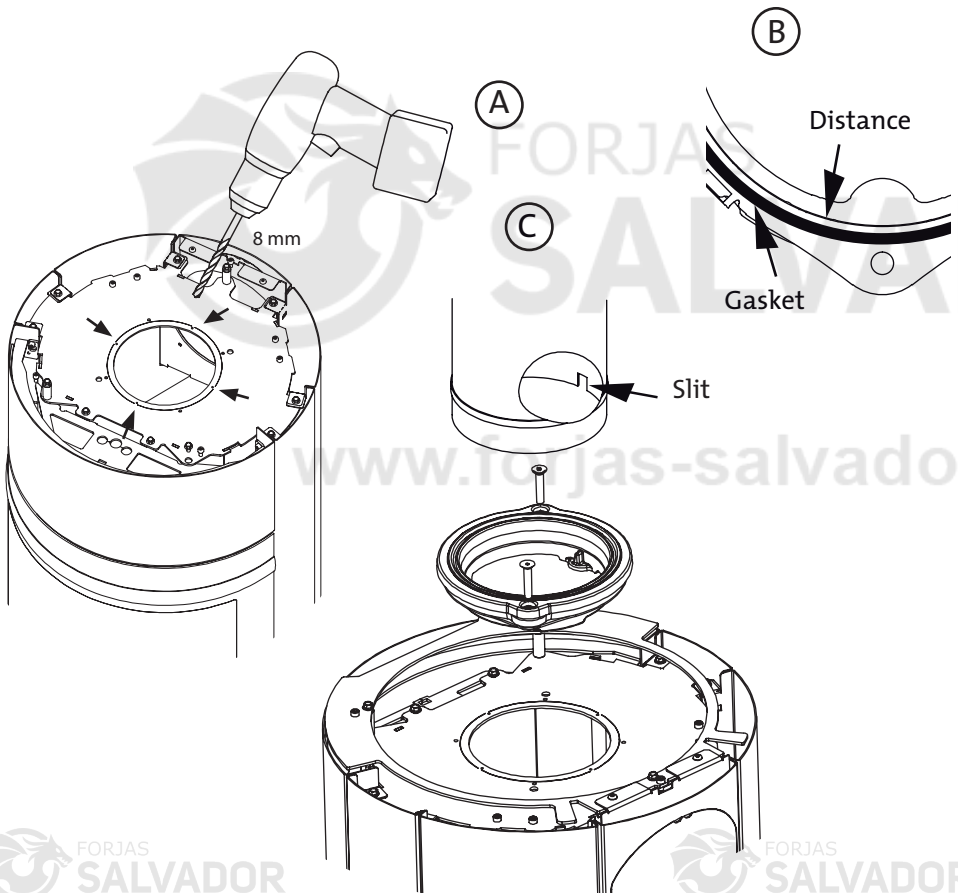

1. Remove the adjustment screws (a).
2. Fasten the revolving plate on the underlay (check that it is level!).  
NB: arrow = front.
3. Mount the lock clips (b), so that the stove complies with the requirements for distance to flammable materials (c).
4. Place the stove on the revolving plate. Adjust, until the bottom plate of the stove covers the revolving plate (a). Do not use the door to lift the stove!

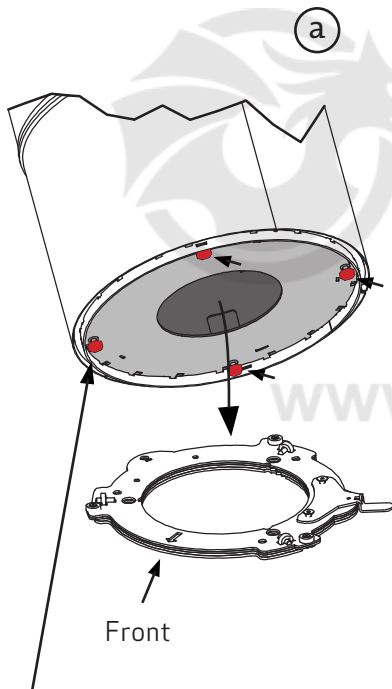

Remove the adjustment screws; then mount the stove on the revolving plate.



(b)

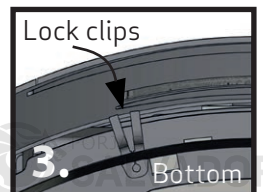
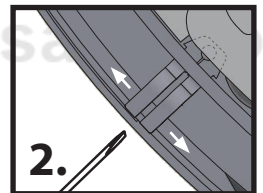
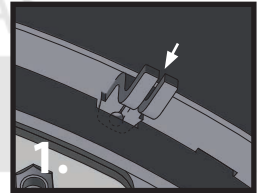

1. Deckplatte entfernen.
2. Die 4 Löcher in der Schablone mit einem 8 mm Bohrer bohren (A) und eventuelle Späne mit einem Staubsauger entfernen.
3. Die Dichtung auf dem Stutzen montieren. Bemerken Sie den Abstand zur Innenseite (B).
4. Den drehbaren Stutzen mit den Schrauben und Muttern montieren.
5. Das Rauchrohr muss mit einem Schlitz versehen sein, der zum Führungzapfen im Stutzen passt. Wenn nicht vorhanden, muss ein Schlitz gemacht werden (C).

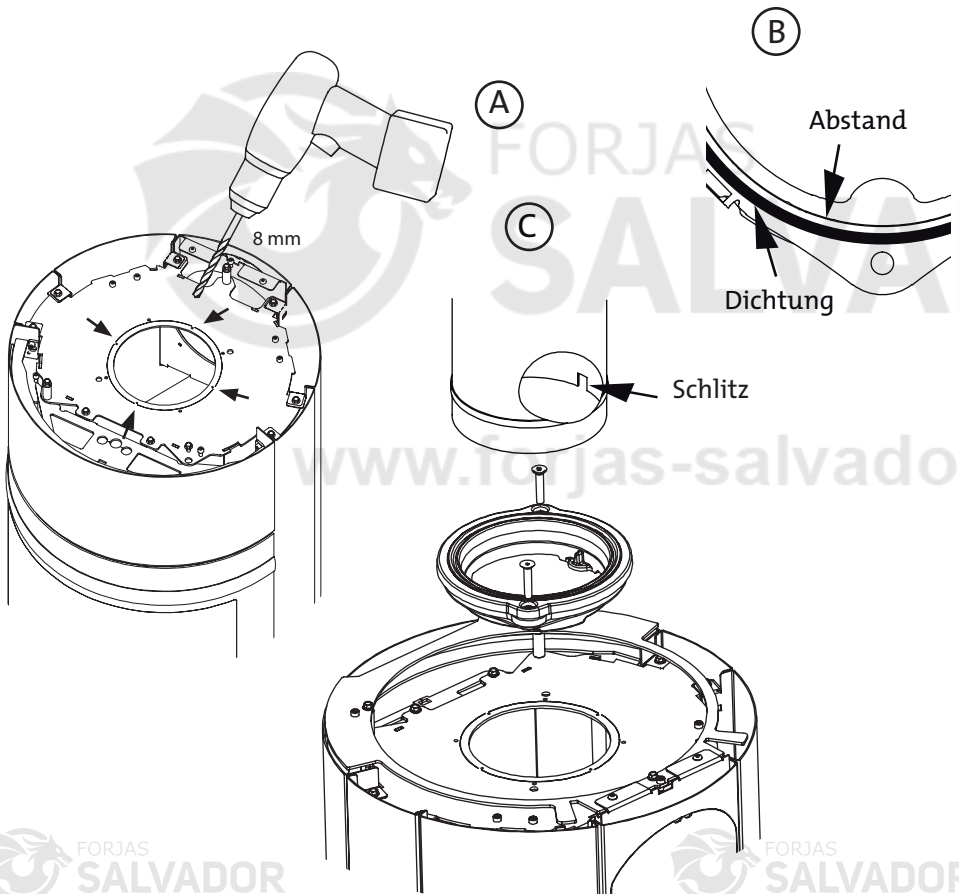

1. Die Justierschrauben des Ofens abmontieren (a).
2. Den Drehfuß auf der Unterlage befestigen (die Unterlage muss ganz waagrecht sein!). NB: Pfeil = Front
3. Arretier-Clips montieren (b), so dass der Ofen die Abstände zu brennbaren Materialien einhält (c).
4. Den Ofen auf dem Drehfuß platzieren. Justieren, bis die Bodenplatte des Ofens den Drehfuß deckt (a). Der Ofen darf nicht mittels der Tür gehoben werden.

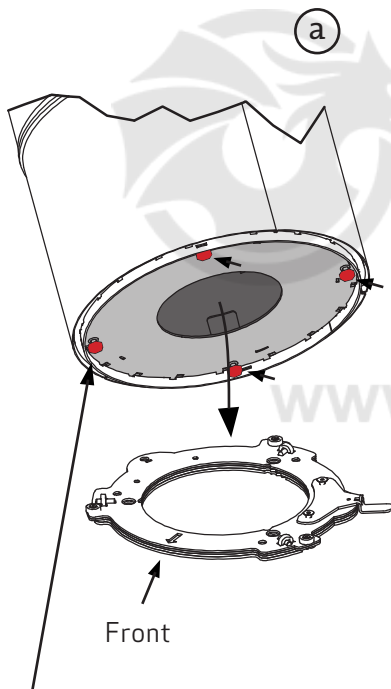

Justierschrauben abmontieren;  
danach den Ofen auf  
dem Drehfuß montieren.



(b)

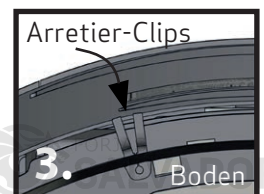
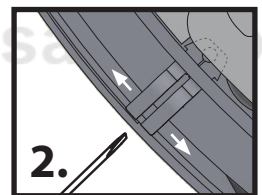
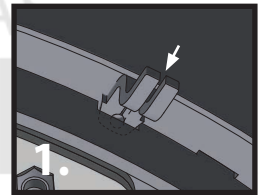

## 6 FR - MONTAGE DE LA PIÈCE DE RACCORDEMENT PIVOTANTE

www.forjas-salvador.com

www.forjas-salvador.com

1. Enlever la plaque supérieure.
2. Forer les quatre trous du patron avec un foret de 8 mm (A) et enlever les résidus avec un aspirateur.
3. Collez le joint sous la buse rotative vers l'extérieur de la gorge (B).
4. Monter la buse rotative avec les vis et les écrous.
5. Le tuyau de raccordement doit être muni d'une fente pour le guide-tenon de la pièce de raccordement (C). Si non, il faut couper une fente.

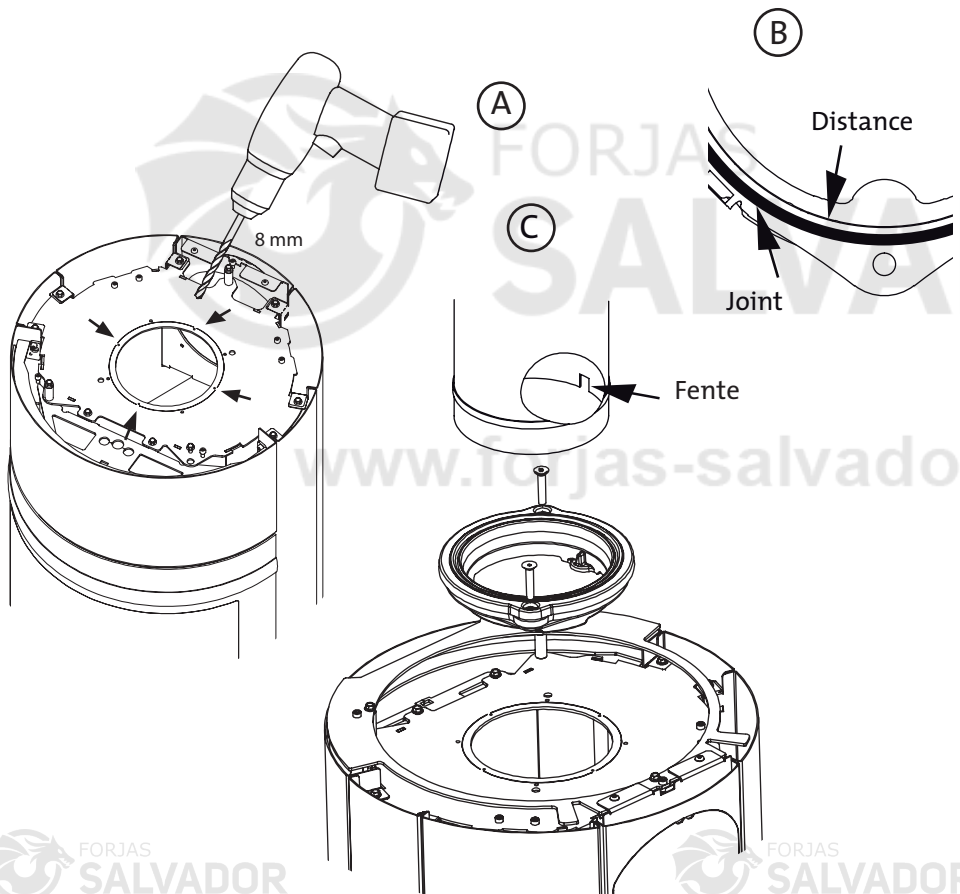

1. Enlever les vis d'ajustement (a).
2. Fixer le plateau rotatif sur le sol qui doit être parfaitement plat.  
NB : Flèche = front.
3. Monter les agrafes (b), de sorte que les distances aux matériaux combustibles soient respectées (c).
4. Placer le poêle sur la base pivotante. Ajuster jusqu'à ce que la plaque de fond du poêle couvre la base pivotante (a). Ne jamais lever le poêle à l'aide de la porte !

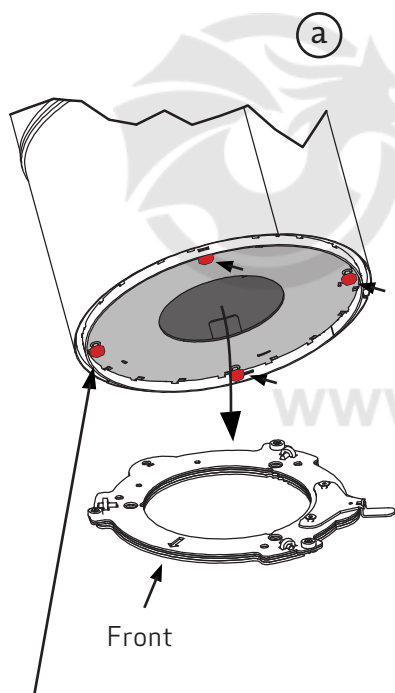

Enlever les vis d'ajustement ;  
puis poser le poêle sur  
la base pivotante.



(b)

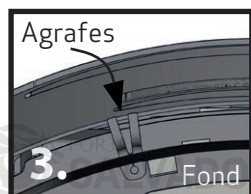
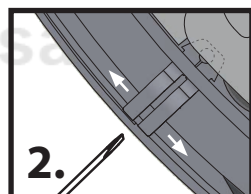
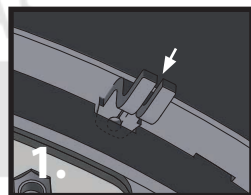

1. Sollevare la piastra superiore.
2. Praticare i quattro fori della sagoma con una punta da trapano da 8 mm. (A) Togliere il materiale residuo ed eliminare eventualmente i trucioli dalla stufa con l'aspirapolvere.
3. Applicare la guarnizione sul raccordo. Fare attenzione a che la guarnizione mantenga la distanza rispetto al lato interno. (B)
4. Inserire il raccordo girevole fissandolo con le due viti ed i bulloni.
5. Tenere presente che la canna fumaria deve essere provvista di una fessura in corrispondenza con il perno di centratura del raccordo della canna fumaria. (C)

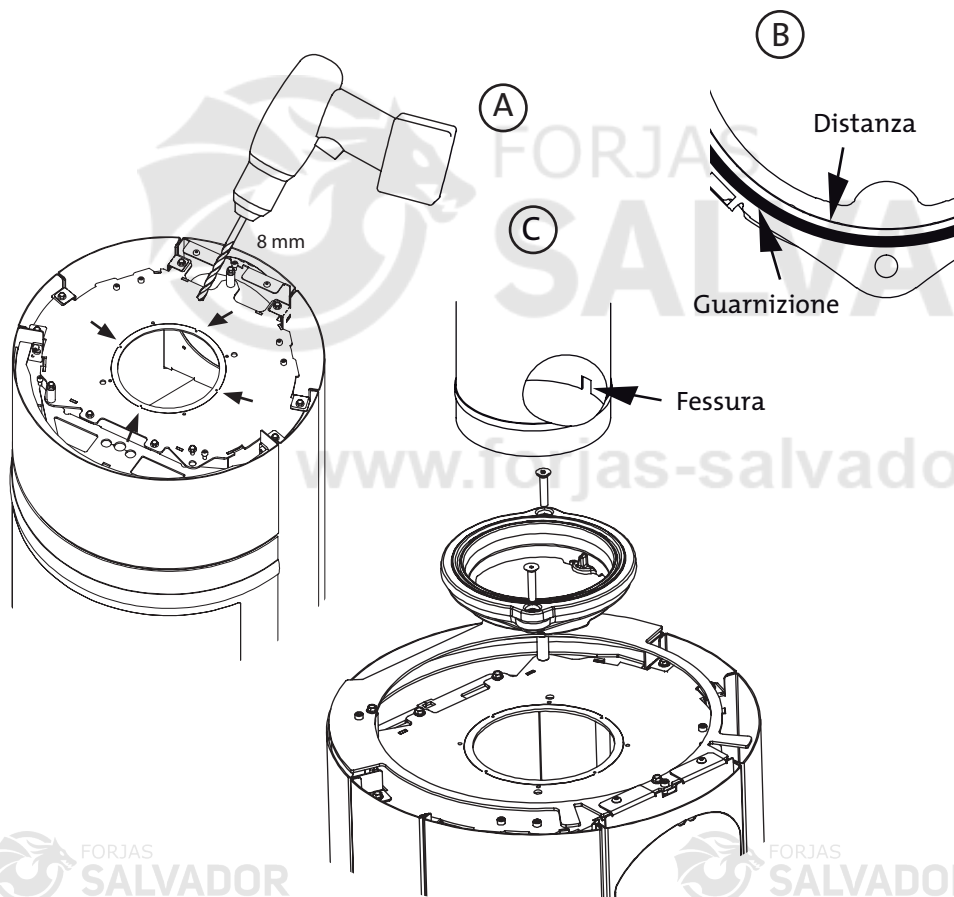

1. Smontare prima le viti di regolazione della stufa. (a)
2. Fissare il supporto girevole sul piano inferiore assicurandosi che questo sia completamente orizzontale. NB.: la freccia indica il lato frontale.
3. L'inserire le graffe di bloccaggio (b) così da rispettare le norme di legge sulla distanza dal materiale infiammabile (c).
4. Sollevare la stufa ponendola sul supporto girevole e regolarne la posizione finché la piastra inferiore della stufa non sia sovrapposta al supporto girevole. (a)  
(Non sollevare la stufa facendo presa sullo sportello)

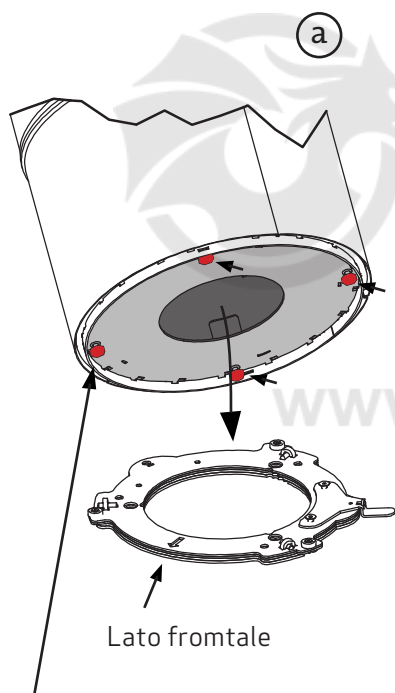

Smontare le viti di regolazione; montare quindi la stufa sul supporto girevole.



(b)

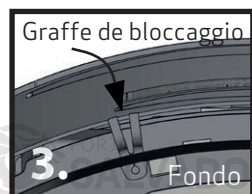
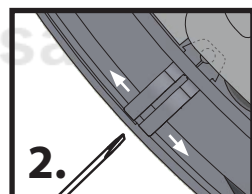
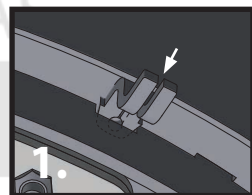

1. Levante la placa superior.
2. Taladre los 4 orificios de la plantilla utilizando una broca de 8 mm. (A)  
Retire el material sobrante y aspire las virutas que hayan podido quedar en la estufa.
3. Coloque la junta en el conector. Deje una separación entre la junta y la cara interior. (B)
4. Coloque el conector giratorio y sujételo con los dos tornillos y las tuercas.
5. El tubo de escape debe estar provisto de una ranura que encaje con la guía del conector. En caso de no tener ranura, debe recortarse una. (C)

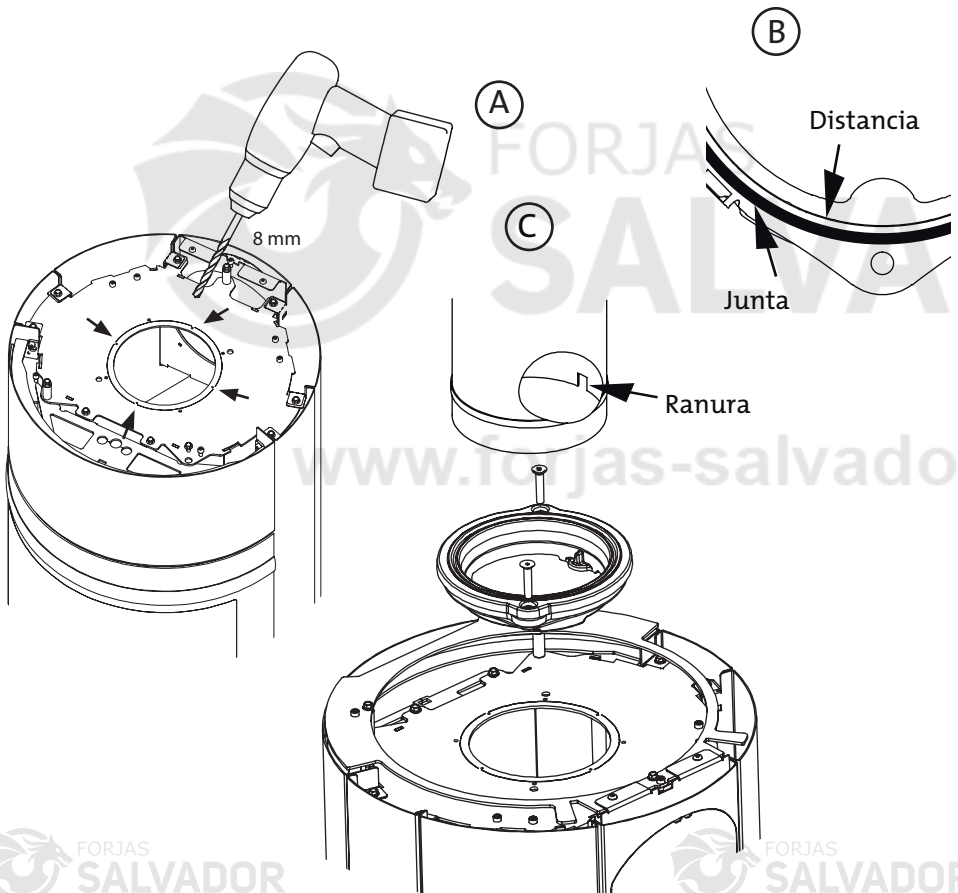

1. Extraiga los tornillos de ajuste. (a)
2. Sujete la base giratoria al soporte, que deberá estar totalmente horizontal. Importante: flecha = parte delantera.
3. Coloque las chavetas (b) de forma que la estufa cumpla los requisitos legales recomendados sobre distancia en relación con materiales inflamables (c).
4. Coloque la estufa sobre la base giratoria y ajústela hasta que la placa inferior cubra la base giratoria. (a) (no utilice la puerta para levantar la estufa)

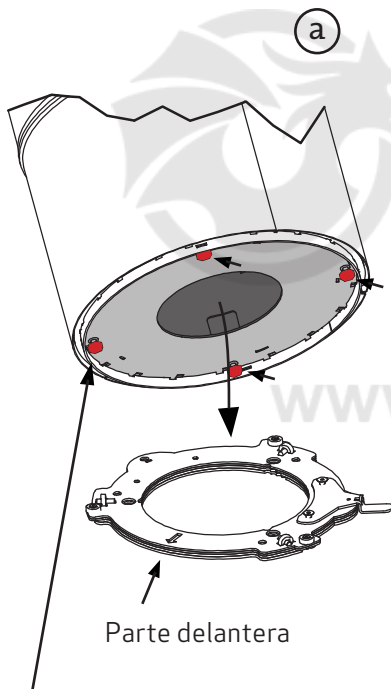

Smontare le viti di regolazione;  
montare quindi la stufa sul  
supporto girevole.



(b)

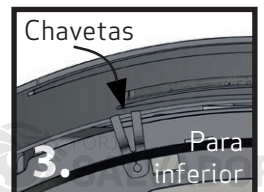
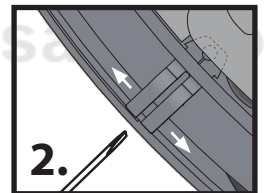
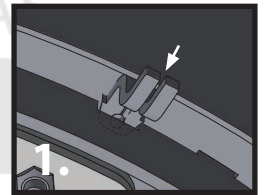

1. Til de bovenplaat eraf.
2. Boor met een 8 mm boor de 4 gaten in de sjabloon. (A) Verwijder het overtollige materiaal en zuig evt. slijpsel in de kachel op.
3. Plaats de pakking op het verloopstuk. Let op: de pakking moet op afstand van de binnenkant blijven. (B)
4. Plaats het draaiverloopstuk en monteer het met de 2 schroeven en meren.
5. Let op: het rookkanaal moet zijn of worden voorzien van een gleuf die geschikt is voor de geleiden in het rookverloopstuk. (C)

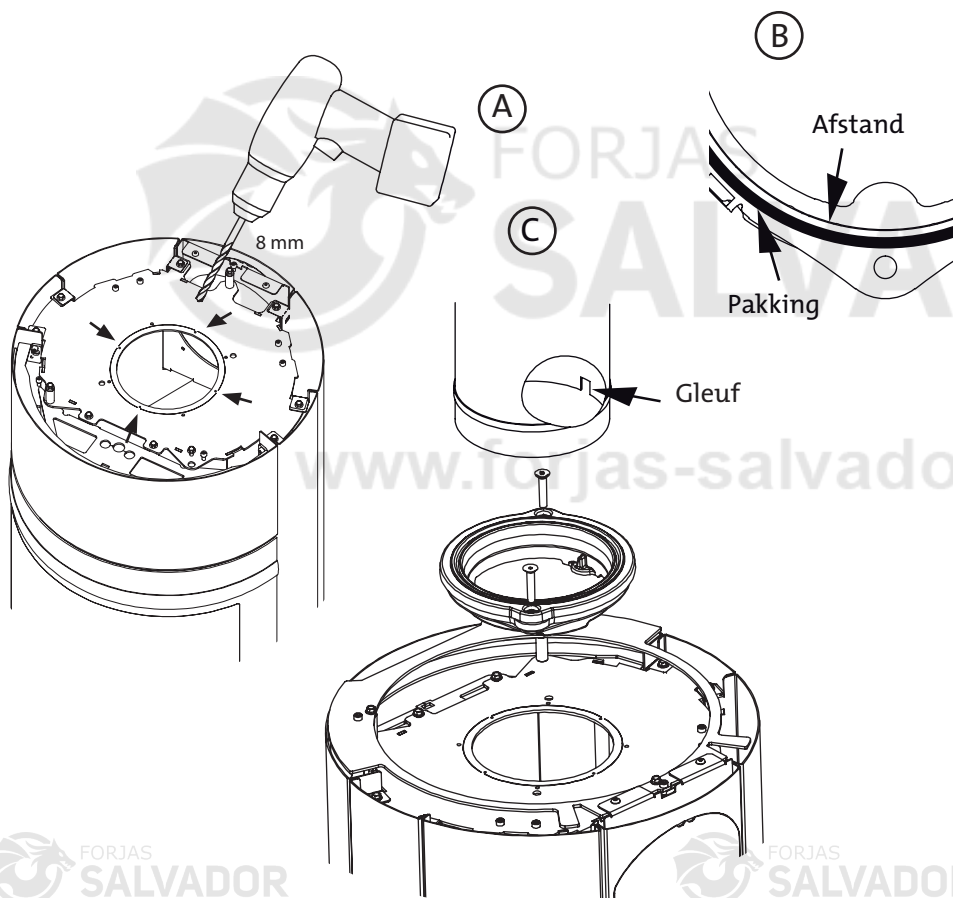

1. Demonteer eerst de stelschroeven van de kachel. (a)
2. Bevestig de draaivoet op de sokkel die volledig horizontaal moet zijn. Let op: pijl = front.
3. Plaats de borgclips (b) zodanig, dat de kachel aan de aanbevolen wettelijke eisen op het gebied van brandbaarheid voldoet (c).
4. Til de kachel op de draaivoet en stel af, totdat de bodemplaat van de kachel over de draaivoet ligt. (a) (til de kachel niet aan het deurtje op)

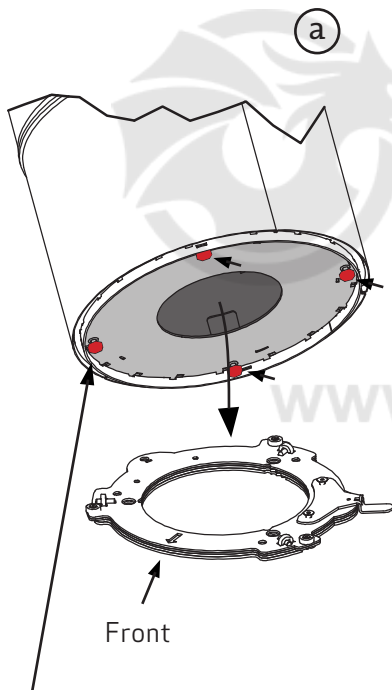

Demonteer de stelschroeven en monteer daarna de kachel op de draaivoet.



(b)

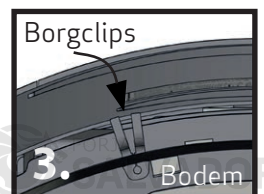
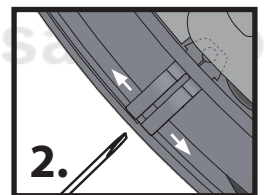
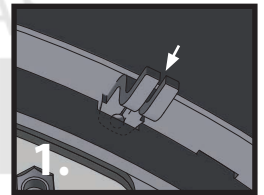

1. Lyft av topplattan.
2. Borra fyra (4) hål i mallen med 8 mm borrh. (A) Ta bort överskottsmaterialet och dammsug spisen så att du får bort eventuella spånor.
3. Sätt fast packningen på stosen. Observera att packningen ska hålla ett avstånd från den invändiga sidan. (B)
4. Sätt in den vridbara stosen och fäst den med de två (2) skruvarna och muttrarna.
5. Observera att rökröret ska vara försett med (eller förses med) ett spår som passar rökstosens styrtapp. (C)

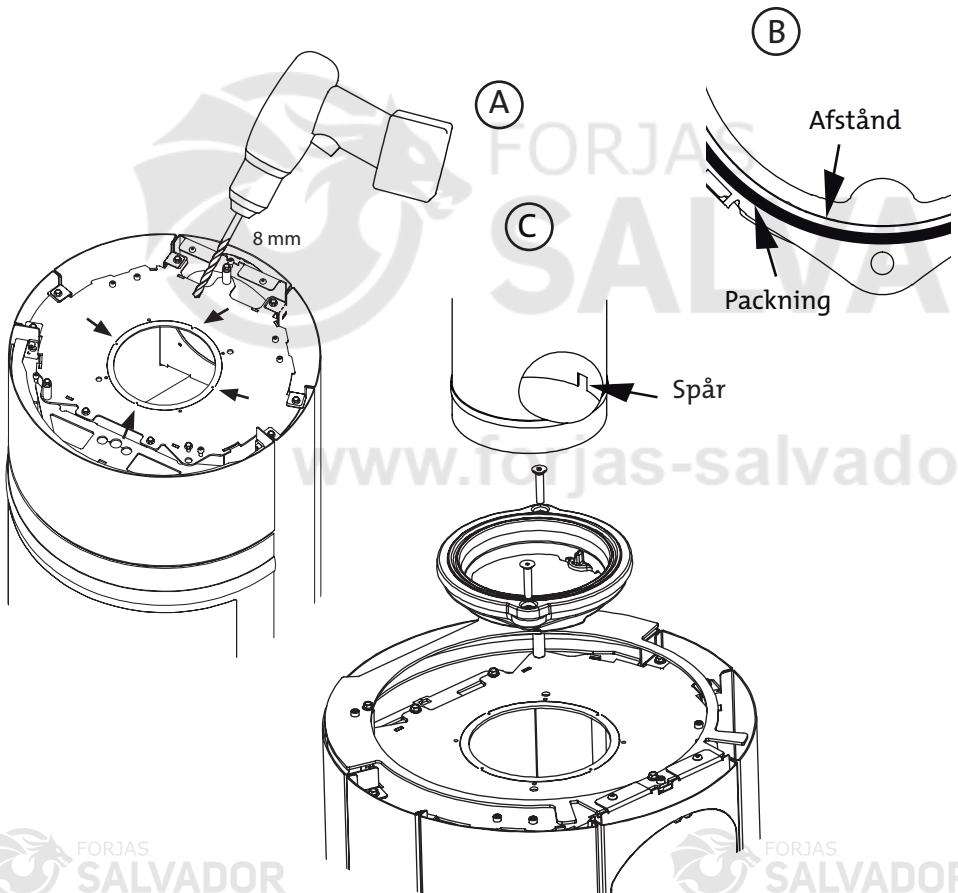

1. Demontera först spisens ställskruvar. (a)
2. Fäst den vridbara foten på underlaget som måste vara helt vågrätt. Observera att pilen = framsidan.
3. Fäst låsklämmorna (b) så att spisen uppfyller de lagstadgade kraven för brandsäkerhet (c).
4. Lyft upp spisen på den vridbara foten och justera den tills att spisens bottenplatta är över den vridbara foten. (a) (lyft inte spisen i luckan)

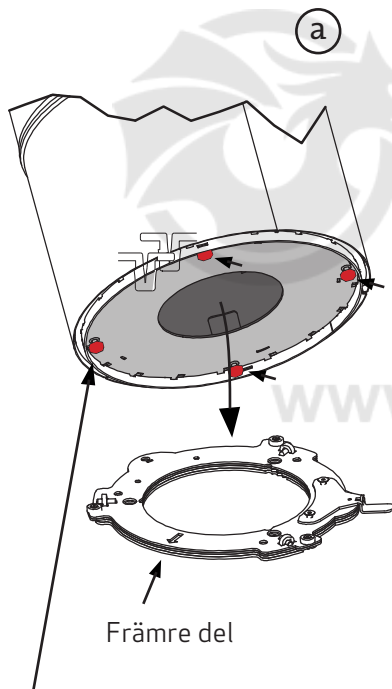

Demontera ställskruvarna och montera därefter spisen på den vridbara foten.



b

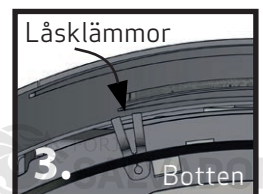
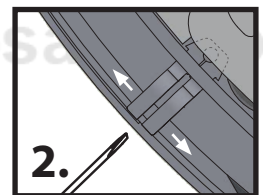
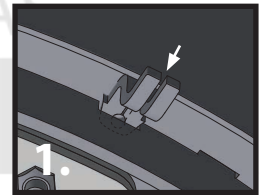

1. Løft av topplaten.
2. Bruk malen og bor 4 hull med 8 mm bor. (A) Fjern det overskytende materialet, og støvsug ev. spon i ovnen.
3. Sett på pakningen på stussen. Det må være en viss avstand mellom pakningen og innsiden. (B)
4. Sett på plass dreiestussen og monter den med de to skruene og mutrene.
5. Vær oppmerksom på at røykrør skal være utstyrt med eller skal utstyres med et spor som passer til styretappen i røykstussen. (C)

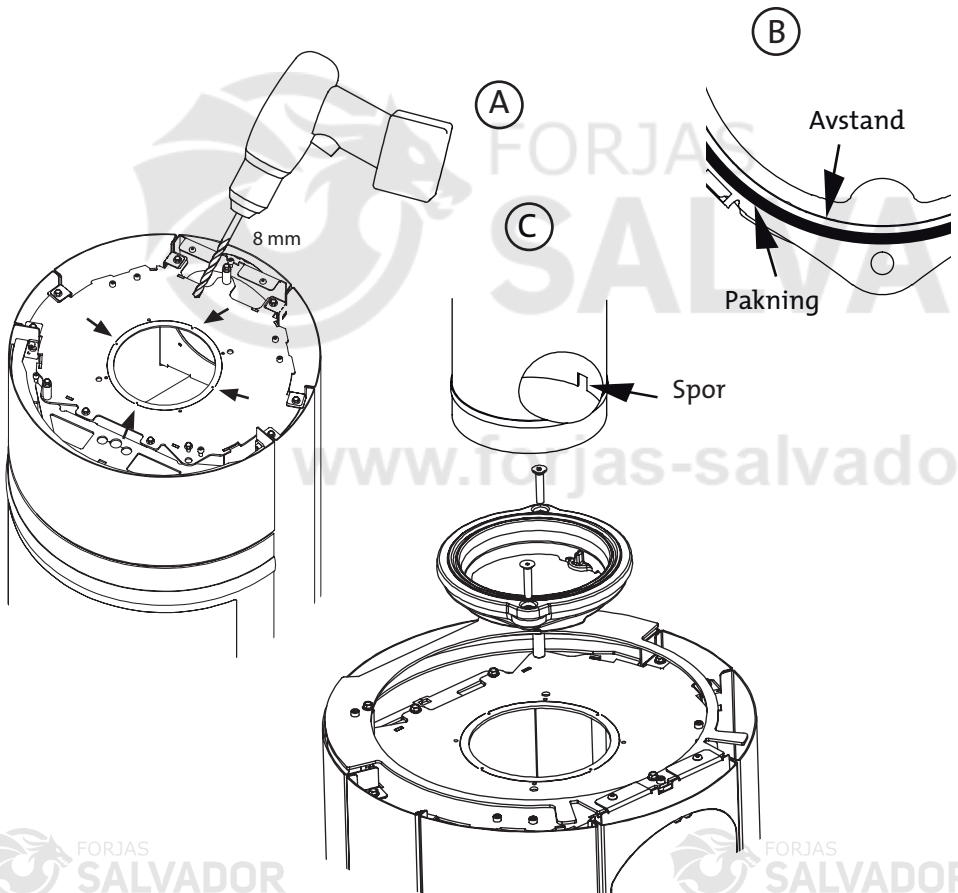

1. Demonter først ovnens justeringskruer. (a)
2. Fest dreiesokkelen på underlaget som skal være helt vannrett. Merk: pil = front.
3. Det benyttes låseklips (b) slik at ovnen overholder anbefalte lovkrav for avstand til brennbart materiale (c).
4. Løft ovnen opp på dreiesokkelen og juster den i forhold til bunnplaten, slik at denne dekkes. (a) (løft ikke ovnen etter døren)

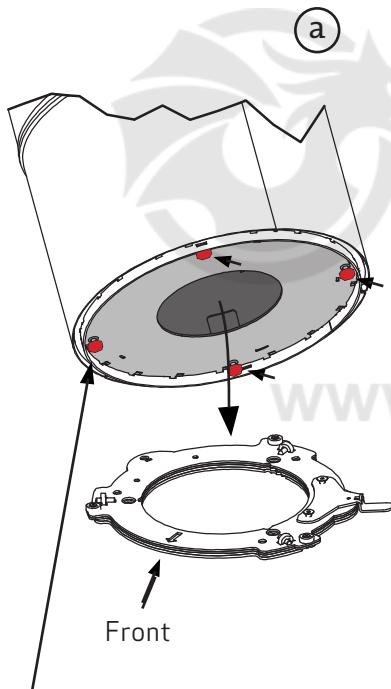

Demonter justeringskrue  
og monter deretter ovnen på  
dreiesokkelen.

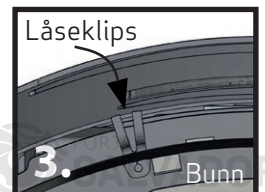
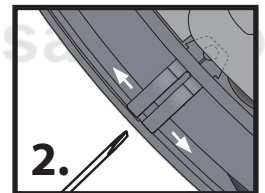
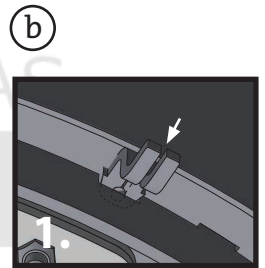

1. Løft toppladen af.
2. Bor med 8 mm bor de 4 huller i skabelonen. (A)  
Fjern det overskydende og støvsug evt. spåner i ovnen.
3. Påsæt pakning på studs. Bemærk pakning skal holde afstand fra indvendig side. (B)
4. Isæt drejestuds og monter med de 2 skruer og møtrikker.
5. Bemærk røgrør skal være forsynet eller skal forsynes med en slids som passer til styretappen i røgstuds. (C)

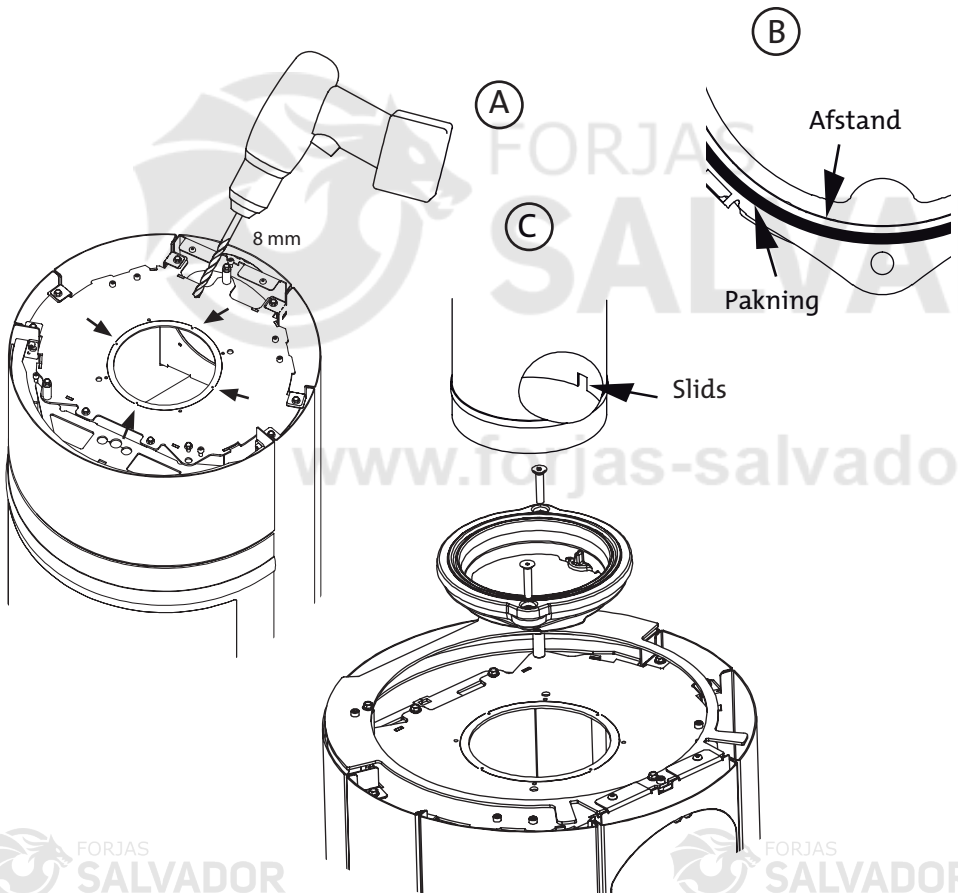

1. Afmonter først ovnens stilleskruer. (a)
2. Fastgør drejefod på underlaget som skal være helt vandret. Bemærk pil = front.
3. Brug nedenstående låseclips til begrænsning af rotation. Låseclips isættes (b) så ovnen overholder anbefalet lovkrav fra brændbart materiale (c).
4. Løft ovnen op på drejefoden og juster indtil ovnens bundplade ligger ud over drejefoden. (a) (løft ikke ovnen i lågen)
5. Træd på pedal og roter ovnen. Ovnens låses i 20 graders positions interval når pedalen slippes (d).

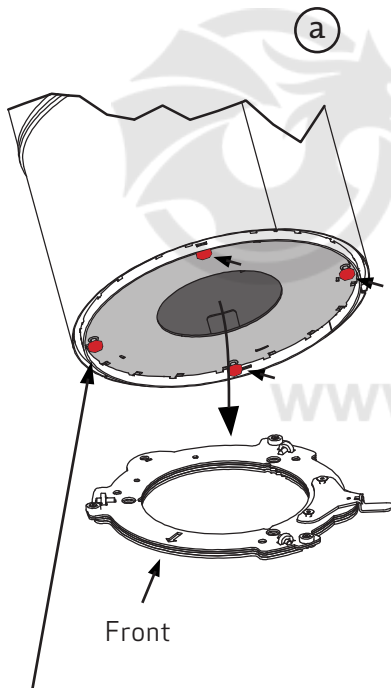

Afmonter stilleskruer, derefter monteres ovnen på drejefoden.



(b)

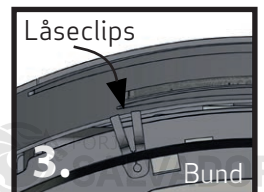
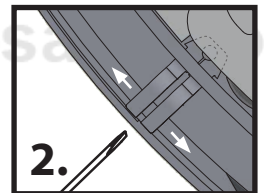
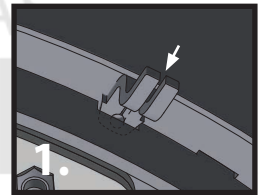

- UK** · Distance to flammable materials - **DE** · Abstand zu brennbaren Materialien  
**FR** · Distance aux matériaux combustibles - **IT** · Distanza dal materiale infiammabile  
**ES** · Distancia en relación con materiales inflamables  
**NL** · Afstand tot brandbaar materiaal - **SE** · Avstånd till brännbart material  
**NO** · Avstand til brennbart materiale - **DK** · Afstand til brændbart materiale

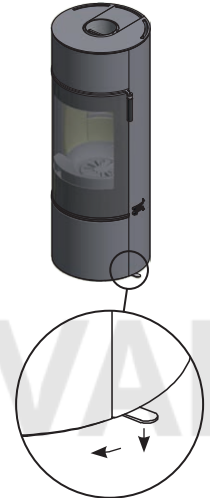
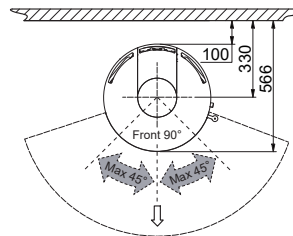
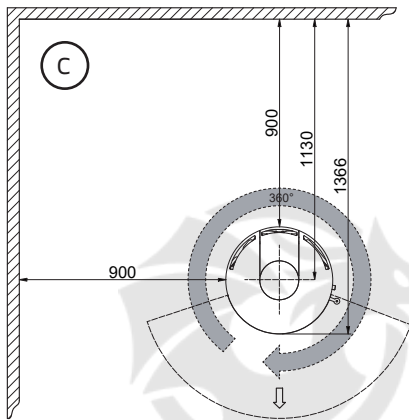

20° positions interval

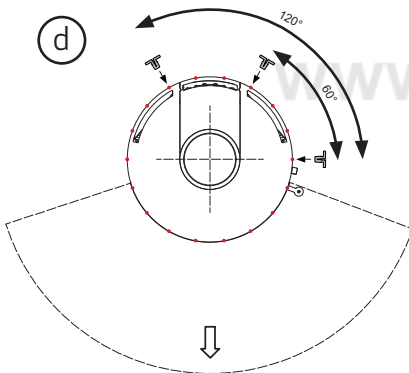

- UK** · Positioning of the lock clips  
**DE** · Platzierung der Arretier-Clips  
**FR** · Placement des agrafes  
**IT** · Posizionamento delle graffe di bloccaggio  
**ES** · Colocación de las chavetas  
**NL** · Plaatsing van borgclips  
**SE** · Låsklämmornas placering  
**NO** · Plassering av låseklips  
**DK** · Placering af låseclips