

AUSTROFLAMM 69X49X57S 2.0 ESQUINERO GUILLOTINA



[Ver más información online](#)



63x40x42 / 63x40x51

69x49x57

89x49x45 / 89x49x57

Operating manual

Sliding corner fireplace in- serts



AUSTROFLAMM

www.austroflamm.com



www.forjas-salvador.com

Original user manual

10/03/2023

Version: 1.0

LEGAL NOTICES

Owner and publisher

AUSTROFLAMM GMBH

Austroflamm-Platz 1

A- 4631 Krenglbach

Tel: +43 (0) 7249 / 46 443

www.austroflamm.com

info@austroflamm.com

Edited by: Olivera Stojanovic

Illustrations: Konstruktion

Text: Technical department (Austroflamm)

Copyright

All Rights reserved. The contents of these instructions may be reproduced or distributed only with the consent of the publisher! Printing, spelling and typographical errors reserved.

Contents

1	General information	6
1.1	Copyright.....	6
1.2	Regulations to be observed	7
2	Purpose of the operating manual	8
2.1	Storing the operating manual	8
2.2	Structure of the operating manual	8
2.3	Representations used.....	8
2.4	Version control.....	8
2.5	Abbreviations	9
3	Safety	10
3.1	Importance of the safety instructions	10
3.2	General safety instructions	10
3.3	Safety distance	11
3.4	Special types of danger and personal protective equipment	11
4	Product overview	12
4.1	Intended use	12
4.2	Identifying the tools.....	12
4.2.1	Design overview	12
4.2.2	Positioning of the nameplates	14
5	Technical data	15
5.1	Technical data under Directive (EU) 2015/1185 and del. as per Regulation (EN) 2015/1186 .	15
5.1.1	63x40x42-S-2.0	15
5.1.2	63x40x51-S-2.0	18
5.1.3	69x49x57-S-2.0	21
5.1.4	89x49x45-S	24
5.1.5	89x49x57-S	27
5.2	General specifications.....	30
5.3	Data for the chimney/flue dimensioning	31
6	Transport and storage	33
6.1	Transportation	33
6.1.1	Transport security	33
6.2	Storage.....	34
7	Requirements at the installation location	35
7.1	Requirements at the room of installation	35
7.2	Installing the fireplace insert	35
7.3	Combustion air supply	35
7.4	Combustion air duct.....	36
7.5	Chimney requirements	36
7.6	Multiple occupancy	37
7.7	Flue pipe connecting pieces.....	37
8	Fuel material/-quantity	38
8.1	Fuel material.....	38

8.2	Fuel quantity.....	40
9	Installation instructions.....	41
9.1	Set-up in front of or next to a wall to be protected.....	41
9.2	Convection air cladding.....	43
9.3	Convection space.....	44
9.4	Convection conduction.....	44
9.5	Fireplace system without air grille (hypocaust).....	45
9.6	Protecting the installation base.....	45
9.7	Expansion joints.....	45
9.8	Cladding.....	45
9.9	Fireplace aprons.....	45
9.10	Ornamental beam.....	45
9.11	Ceiling above the fireplace insert.....	46
9.12	Floor in front of the fireplace insert.....	46
9.13	Fire protection.....	46
9.14	Heat insulation layers and materials.....	46
9.15	Electric cable runs.....	48
9.16	Balanced flue-tested fireplace inserts.....	48
10	Connection to ceramic flues.....	49
10.1	Stove with ceramic flue.....	50
10.2	Connection to heat recovery surfaces.....	51
11	Installation.....	52
11.1	Risks and dangers.....	52
11.2	Durchführung.....	52
11.2.1	Placing the fireplace insert.....	52
11.2.2	Installing the deflector plates.....	53
11.2.3	Installing the firebox lining (Keramott).....	54
11.2.4	Removing the door.....	56
11.2.5	Converting door to type BA2.....	58
11.2.6	Converting the flue pipe.....	58
11.2.7	Installing the HMS.....	60
11.2.8	Mounting small top storage box.....	61
11.2.9	Assembling InsertControl.....	64
11.2.10	Mounting the convection cladding.....	71
11.2.11	Mounting the design frame.....	72
11.2.12	Solidly mounting the design frame.....	73
11.2.13	Support frame.....	77
12	Settings.....	78
12.1	Adjusting the tuning weight.....	78
13	Commissioning.....	80
13.1	Initial Commissioning.....	80
14	Operation.....	81
14.1	Controls.....	81
14.2	Before heating up.....	81
14.3	Fuel.....	82



14.4 Firing 82

14.5 Heating..... 83

14.6 Putting on wood 83

14.7 Heating in the transition period..... 84

14.8 Heating with the ceramic flue (heat recovery surface)..... 84

14.9 Operation 85

15 Cleaning..... 86

15.1 Cleaning fireplace insert, fuel gas flues..... 86

15.2 Removing ashes..... 86

15.3 Cleaning the washers on the door 86

16 Help 88

16.1 Firebox lining 89

16.2 What to do in the event of a chimney fire..... 89

16.3 What to do in the event of faults..... 89

17 Spare parts..... 90

18 Dismantling 91

19 Disposal..... 92

20 Warranty and guarantee 94

21 Start up log 95

22 Service Report..... 96



1 General information

You have decided in favour of an Austroflamm fireplace insert.

Congratulations on your decision and thank you for your trust.

Correct operation and care are essential for trouble-free operation and long service life. Likewise, please follow the instructions in the operating manual.

The information in this manual is of a general nature. National and European standards, local and building regulations, together with fire regulations must be complied with.

Read these instruction through carefully before installation and operation. No liability or warranty claims apply for damage incurred by failure to follow this manual. Please observe the instructions in the individual sections.

TIP

Please arrange the set-up location and connection to the chimney with the master chimney sweep.

This manual is enclosed with your Austroflamm fireplace insert. In the following list we give you an overview of which sections are important for whom:

Dealer	End customer
	General information
	Purpose of the manual
	Safety
	Product overview
	Technical data
	Transport and storage
	Requirements at the installation location
	Fuel material/-quantity
	Installation instructions
	Commissioning
	Operation
	Cleaning
	Help
	Spare parts
	Dismantling
	Disposal
	Guarantee and warranty
	Data processing
	Start up log
	Service Report

1.1 Copyright

All Rights reserved. The contents of these instructions may be reproduced or distributed only with the consent of the publisher! Printing, spelling and typographical errors reserved.



1.2 Regulations to be observed

- EN 13229
- DIN 18896
- DIN EN 13384 Part 1 and Part 2
- DIN 18160-1 Exhaust systems - Part 1
- EN 12831
- State building regulations of the individual federal states or countries.
- Heating regulations of the individual federal states or countries.
- Technical rules of the stove- and air heating constructors trade association (TR OL) or technical rules of other countries
- Federal Emission Control Ordinance (BImSchV)



FORJAS
SALVADOR

www.forjas-salvador.com



2 Purpose of the operating manual

This manual is a component part of the fireplace insert and contributes towards the fireplace insert being safely installed and maintained.

TIP

Please read this manual before using commissioning or installation.

2.1 Storing the operating manual

Store this manual in case you need it. The current version of the manual can be found on-line at our homepage www.austroflamm.com.

2.2 Structure of the operating manual

The table of contents can be found on page 3.

Illustrations in this manual may differ from the delivered product.

2.3 Representations used

The following representations are used in this manual:

Steps with mandatory adherence to the sequence

✓ Prerequisite

1) Step 1

2) Step 2

3)

⇒ Intermediate result / additional information

⇒ Result

Steps and bullet points without mandatory sequence

•

•

-

-

Cross-references

See Technical Data

Useful tips

TIP

Fuel

Use only recommended fuel!

2.4 Version control

We update our manuals on a continual basis. The current version can be found at our homepage www.austroflamm.com.



2.5 Abbreviations

Abbreviation	Meaning
HMS	Heat Memory System
FI	Fireplace insert
CF	Ceramic flue
CVC	Convection cladding



FORJAS

SALVADOR

www.forjas-salvador.com

3 Safety

In this manual we give you numerous safety instructions for the safe operation of your fireplace insert. These instructions are characterized differently as follows, depending on their importance:

3.1 Importance of the safety instructions

NOTICE

Particular behaviour and/or activities that are required for safe working. Failure to follow this can result in material damage.

CAUTION

Possible dangerous situation (light or minor injuries and material damage).

WARNING

Possibly imminent danger to life and health of persons (severe injuries or death).

DANGER

Immediately imminent danger to life and health of persons (severe injuries or death).

3.2 General safety instructions

- It is strictly forbidden to burn or introduce highly flammable or explosive substances, (such as empty aerosols and the like) into the firebox or to store them in the immediate vicinity of the fireplace due to the risk of explosion!
- Please note that the the surfaces of the fireplace insert heat up considerably during operation. To operate your fireplace insert, we recommend that you use the protective glove supplied with it. Please alert children to these dangers, and keep them away from the heat-producing appliance when it is operating.
- Placing non-heat-resistant objects on the stove or in its vicinity is forbidden. This also applies to airers -> fire hazard!
- While the heat-producing appliance is in operation, it is forbidden to process highly flammable or explosive substances in the same room or in adjoining rooms.
- To avoid a build-up of heat in the chimney, the warm air grilles must not be closed during heating operation.
- Fireplace inserts tested to type A1 are fitted with a self-closing firebox door. This means that operating with the firebox door open is not permissible. To stoke up the wood the hinged door must be kept open against the tension force of the springs. The door must not be jammed open with clamping devices.
- Only spare parts which are specifically approved or offered by the manufacturer may be used. Please contact your specialist dealer if necessary. Failure to comply with this may cause loss of warranty!

Please also read further information in the section Fuel.





3.3 Safety distance

No flammable objects may be placed within the radiation area of the fireplace insert up to a certain distance (see Technical Data) measured from the front edge of the firebox opening (a minimum clearance in the Technical Data).

3.4 Special types of danger and personal protective equipment

For certain activities such as installation/dismantling, particular care must be taken that the following safety equipment is worn:

	Safety gloves
	Safety shoes



4 Product overview

4.1 Intended use

The Austroflam fireplace inserts described in this manual are manufactured and tested with a type A1 self-closing and locking door under EN test EN 13229.

NOTICE

Operation is only permissible with the door closed.

4.2 Identifying the tools

In the following illustrations we give an overview of the most important dimensions and the nameplate positioning.

4.2.1 Design overview

63x40x42/51 S 2.0 left/right	42 S	51 S
	Width (body installation dimension) [mm]	630
	Door frame, height [mm]	420 / 510
	Pane curvature	Corner, 90°
	Width [mm]	720
	Depth [mm]	490
	Height [mm]	1137-1337 / 1313-1513
	Weight [kg]	185 / 195
	Nominal heat efficiency [kW]	8 / 12
	Flue pipe outlet, diameter [mm]	Ø 150

**69x49x57 S 2.0 left/right**

	Width (body installation dimension) [mm]	690
	Door frame, height [mm]	570
	Pane curvature	Corner, 90°
	Width [mm]	780
	Depth [mm]	580
	Height [mm]	1384-1584
	Weight [kg]	231
	Nominal heat efficiency [kW]	12
	Flue pipe outlet, diameter [mm]	Ø180

89x49x45/57 left/right

	x45	x57	
	Width (body installation dimension) [mm]	890	890
	Door frame, height [mm]	450	570
	Pane curvature	Corner, 90°	Corner, 90°
	Width [mm]	977	977
	Depth [mm]	568	568
	Height [mm]	1209-1409	1389-1589
	Weight [kg]	216	222
	Nominal heat efficiency [kW]	12	12
	Flue pipe outlet, diameter [mm]	Ø 180	Ø 180



4.2.2 Positioning of the nameplates

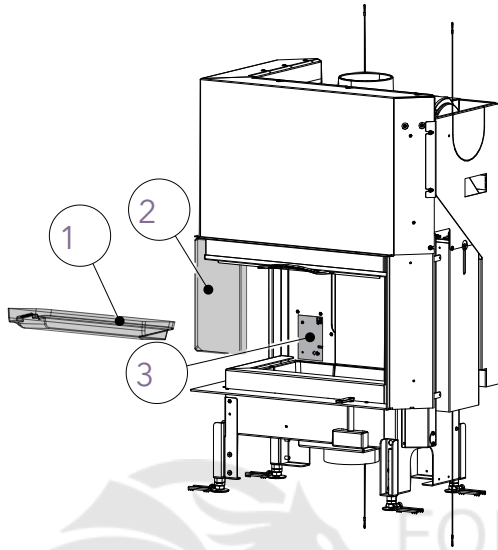

On corner appliances the nameplate (3) is located on the rear panel behind the Keramott (2), next to the door hinge. First remove the baffle plate (1) and then the rear Keramott (2) (left or right).

Fig. 1: Corner appliance nameplate

FORJAS
SALVADOR
www.forjas-salvador.com

5 Technical data

5.1 Technical data under Directive (EU) 2015/1185 and del. as per Regulation (EN) 2015/1186

5.1.1 63x40x42-S-2.0

Contact details for the manufacturer or their authorized representative

Manufacturer:	Austroflamm GmbH
Contact:	-
Address:	Austroflamm-Platz 1 4631 Krenglbach Austria

Appliance details

Model identification(s):	63x40x42-S-2.0
Equivalent models:	-
Test reports:	DBI F 17/05/0478
Applied harmonized standards:	EN 13229
Other standards/technical specifications Specifications:	-
Indirect heating function:	no
Direct heat output:	8 kW
Indirect heat output ¹ :	-

Properties for operation with the preferred fuel

Space heating annual use efficiency η_s :	72 %
Energy efficiency index (EEI):	108

Particular precautions for assembly, installation or maintenance

Described in the individual sections of the operating manual.

Fuel	Preferred fuel (only one) ² :	Other suitable fuel(s) ³ :	η_s [x%]:	Space heating emissions at nominal heat efficiency (*)				Space heating emissions at minimum heat efficiency ⁴ (*) (**)			
				PM	OGC	CO	NOx	PM	OGC	CO	NOx
				[x] mg/Nm ³ (13% O ₂) ⁵				[x] mg/Nm ³ (13% O ₂) ⁶			
Log, moisture content ≤ 25 %	yes	no	72	30	47	877	108	-	-	-	-
Compregnated laminated wood, Moisture content < 12 %	no	no	-	-	-	-	-	-	-	-	-
Other woody biomass	no	no	-	-	-	-	-	-	-	-	-
Non-woody biomass	no	no	-	-	-	-	-	-	-	-	-
Anthracite and dry steam coal	no	no	-	-	-	-	-	-	-	-	-
Coking coal	no	no	-	-	-	-	-	-	-	-	-
Semi-coke	no	no	-	-	-	-	-	-	-	-	-
Bituminous coal	no	no	-	-	-	-	-	-	-	-	-
Lignite briquettes	no	no	-	-	-	-	-	-	-	-	-
Peat briquettes	no	no	-	-	-	-	-	-	-	-	-
Briquettes made from a mixture of fossil fuels	no	no	-	-	-	-	-	-	-	-	-
Other fossil fuels	no	no	-	-	-	-	-	-	-	-	-
Briquettes made from a mixture of biomass and fossil fuels	no	no	-	-	-	-	-	-	-	-	-
Other mixture of biomass and solid fuels	no	no	-	-	-	-	-	-	-	-	-

(*) PM = dust, OGC = organic gaseous connections, CO = carbon monoxide, NOx = nitrogen oxide

(**) Only required when using correction factors F(2) or F(3).

Properties for exclusive operation with the preferred fuels⁷

Specification	Symbol	Value	Unit	Specification	Symbol	Value	Unit
Heat output				Thermal efficiency (fuel efficiency) (based on the NCV)			
Nominal heat efficiency	P _{nom}	8	kW	thermal efficiency (fuel efficiency) at nominal heat efficiency	η _{th,nom}	82	%
Minimum heat output (standard value)	P _{min}	-	kW	thermal efficiency (fuel efficiency) at minimum heat output (standard value)	η _{th,min}	-	%
Auxiliary power consumption				Type of heat output/room temperature control			
At nominal heat efficiency	e _{lmax}	-	kW	single-level heat output, no room temperature control			yes
At minimum heat output	e _{lmin}	-	kW	two or more manually adjustable levels, no room temperature control			no
In standby condition	e _{lSB}	-	kW	Room temperature control with mechanical thermostat			no
Pilot flame power requirement				with electronic room temperature control			
Pilot flame power requirement (if present)	P _{pilot}	-	kW	with electronic room temperature control and daytime regulation			no
				with electronic room temperature control and weekday regulation			
				Other regulation options (Multiple answers possible)			
				Room temperature control with presence detection			no
				Room temperature control with open window detection			no
				with remote control option			no

¹ There is no entry for fireplaces without water-carrying components.

² Values for annual use efficiency and emissions must be given here for the preferred fuel.

³ Values for annual use efficiency and emissions must be given here for all other suitable fuels.

⁴ Corresponds to partial load heat output as per EN 16510

⁵ Specification in mg/m³ for heated filter method (in compliance with Annexe III, number 4, letter a, section i, point 1) or g/kg for measurement in dilution tunnel (in compliance with Annexe III, number 4, letter a, section i, point 2 and 3.)

⁶ Specification mg/m³ for heated filter method (in compliance with Annexe III, number 4, letter a, section i, point 1) or g/kg for measurement in dilution tunnel (in compliance with Annexe III, number 4, letter a, section i, point 2 and 3.)

⁷ Specifications are made here for the preferred fuel only.

5.1.2 63x40x51-S-2.0

Contact details for the manufacturer or their authorized representative

Manufacturer:	Austroflamm GmbH
Contact:	-
Address:	Austroflamm-Platz 1 4631 Krenglbach Austria

Appliance details

Model identification(s):	63x40x51-S-2.0
Equivalent models:	-
Test reports:	SZU 30-14842T
Applied harmonized standards:	EN 13229
Other standards/technical specifications Specifications:	-
Indirect heating function:	no
Direct heat output:	12 kW
Indirect heat output ¹ :	-

Properties for operation with the preferred fuel

Space heating annual use efficiency η_s :	71 %
Energy efficiency index (EEI):	107

www.forjas-salvador.com

Particular precautions for assembly, installation or maintenance

Described in the individual sections of the operating manual.

Fuel	Preferred fuel (only one) ² :	Other suitable fuel(s) ³ :	η_s [x%]:	Space heating emissions at nominal heat efficiency (*)				Space heating emissions at minimum heat efficiency ⁴ (*) (**)			
				PM	OGC	CO	NOx	PM	OGC	CO	NOx
				[x] mg/Nm ³ (13% O ₂) ⁵				[x] mg/Nm ³ (13% O ₂) ⁶			
Log, moisture content ≤ 25 %	yes	no	71	27	50	704	113	-	-	-	-
Compregnated laminated wood, Moisture content < 12 %	no	no	-	-	-	-	-	-	-	-	-
Other woody biomass	no	no	-	-	-	-	-	-	-	-	-
Non-woody biomass	no	no	-	-	-	-	-	-	-	-	-
Anthracite and dry steam coal	no	no	-	-	-	-	-	-	-	-	-
Coking coal	no	no	-	-	-	-	-	-	-	-	-
Semi-coke	no	no	-	-	-	-	-	-	-	-	-
Bituminous coal	no	no	-	-	-	-	-	-	-	-	-
Lignite briquettes	no	no	-	-	-	-	-	-	-	-	-
Peat briquettes	no	no	-	-	-	-	-	-	-	-	-
Briquettes made from a mixture of fossil fuels	no	no	-	-	-	-	-	-	-	-	-
Other fossil fuels	no	no	-	-	-	-	-	-	-	-	-
Briquettes made from a mixture of biomass and fossil fuels	no	no	-	-	-	-	-	-	-	-	-
Other mixture of biomass and solid fuels	no	no	-	-	-	-	-	-	-	-	-

(*) PM = dust, OGC = organic gaseous connections, CO = carbon monoxide, NOx = nitrogen oxide

(**) Only required when using correction factors F(2) or F(3).

Properties for exclusive operation with the preferred fuels⁷

Specification	Symbol	Value	Unit	Specification	Symbol	Value	Unit
Heat output				Thermal efficiency (fuel efficiency) (based on the NCV)			
Nominal heat efficiency	P _{nom}	12	kW	thermal efficiency (fuel efficiency) at nominal heat efficiency	η _{th,nom}	81	%
Minimum heat output (standard value)	P _{min}	-	kW	thermal efficiency (fuel efficiency) at minimum heat output (standard value)	η _{th,min}	-	%
Auxiliary power consumption				Type of heat output/room temperature control			
At nominal heat efficiency	el _{max}	-	kW	single-level heat output, no room temperature control			yes
At minimum heat output	el _{min}	-	kW	two or more manually adjustable levels, no room temperature control			no
In standby condition	e _{lSB}	-	kW	Room temperature control with mechanical thermostat			no
Pilot flame power requirement				with electronic room temperature control			
Pilot flame power requirement (if present)	P _{pilot}	-	kW	with electronic room temperature control and day-time regulation			no
				with electronic room temperature control and weekday regulation			no
				Other regulation options (Multiple answers possible)			
				Room temperature control with presence detection			no
				Room temperature control with open window detection			no
				with remote control option			no

¹ There is no entry for fireplaces without water-carrying components.

² Values for annual use efficiency and emissions must be given here for the preferred fuel.

³ Values for annual use efficiency and emissions must be given here for all other suitable fuels.

⁴ Corresponds to partial load heat output as per EN 16510

⁵ Specification in mg/m³ for heated filter method (in compliance with Annexe III, number 4, letter a, section i, point 1) or g/kg for measurement in dilution tunnel (in compliance with Annexe III, number 4, letter a, section i, point 2 and 3.)

⁶ Specification mg/m³ for heated filter method (in compliance with Annexe III, number 4, letter a, section i, point 1) or g/kg for measurement in dilution tunnel (in compliance with Annexe III, number 4, letter a, section i, point 2 and 3.)

⁷ Specifications are made here for the preferred fuel only.

5.1.3 69x49x57-S-2.0

Contact details for the manufacturer or their authorized representative

Manufacturer:	Austroflamm GmbH
Contact:	-
Address:	Austroflamm-Platz 1 4631 Krenglbach Austria

Appliance details

Model identification(s):	69x49x57-S-2.0
Equivalent models:	-
Test reports:	DBI F 19/12/0711
Applied harmonized standards:	EN 13229
Other standards/technical specifications Specifications:	-
Indirect heating function:	no
Direct heat output:	12 kW
Indirect heat output ¹ :	-

Properties for operation with the preferred fuel

Space heating annual use efficiency η_s :	72 %
Energy efficiency index (EEI):	108

www.forjas-salvador.com

Particular precautions for assembly, installation or maintenance

Described in the individual sections of the operating manual.

Fuel	Preferred fuel (only one) ² :	Other suitable fuel(s) ³ :	η_s [x%]:	Space heating emissions at nominal heat efficiency (*)				Space heating emissions at minimum heat efficiency ⁴ (*) (**)			
				PM	OGC	CO	NOx	PM	OGC	CO	NOx
				[x] mg/Nm ³ (13% O ₂) ⁵				[x] mg/Nm ³ (13% O ₂) ⁶			
Log, moisture content ≤ 25 %	yes	no	72	29	68	1179	101	-	-	-	-
Compregnated laminated wood, Moisture content < 12 %	no	no	-	-	-	-	-	-	-	-	-
Other woody biomass	no	no	-	-	-	-	-	-	-	-	-
Non-woody biomass	no	no	-	-	-	-	-	-	-	-	-
Anthracite and dry steam coal	no	no	-	-	-	-	-	-	-	-	-
Coking coal	no	no	-	-	-	-	-	-	-	-	-
Semi-coke	no	no	-	-	-	-	-	-	-	-	-
Bituminous coal	no	no	-	-	-	-	-	-	-	-	-
Lignite briquettes	no	no	-	-	-	-	-	-	-	-	-
Peat briquettes	no	no	-	-	-	-	-	-	-	-	-
Briquettes made from a mixture of fossil fuels	no	no	-	-	-	-	-	-	-	-	-
Other fossil fuels	no	no	-	-	-	-	-	-	-	-	-
Briquettes made from a mixture of biomass and fossil fuels	no	no	-	-	-	-	-	-	-	-	-
Other mixture of biomass and solid fuels	no	no	-	-	-	-	-	-	-	-	-

(*) PM = dust, OGC = organic gaseous connections, CO = carbon monoxide, NOx = nitrogen oxide

(**) Only required when using correction factors F(2) or F(3).

Properties for exclusive operation with the preferred fuels⁷

Specification	Symbol	Value	Unit	Specification	Symbol	Value	Unit	
Heat output				Thermal efficiency (fuel efficiency) (based on the NCV)				
Nominal heat efficiency	P _{nom}	12	kW	thermal efficiency (fuel efficiency) at nominal heat efficiency	η _{th,nom}	82	%	
Minimum heat output (standard value)	P _{min}	-	kW	thermal efficiency (fuel efficiency) at minimum heat output (standard value)	η _{th,min}	-	%	
Auxiliary power consumption				Type of heat output/room temperature control				
At nominal heat efficiency	e _{lmax}	-	kW	single-level heat output, no room temperature control			yes	
At minimum heat output	e _{lmin}	-	kW	two or more manually adjustable levels, no room temperature control			no	
In standby condition	e _{lSB}	-	kW	Room temperature control with mechanical thermostat			no	
Pilot flame power requirement				with electronic room temperature control				
Pilot flame power requirement (if present)	P _{pilot}	-	kW	with electronic room temperature control and day-time regulation			no	
				with electronic room temperature control and weekday regulation				
				Other regulation options (Multiple answers possible)				
				Room temperature control with presence detection				no
				Room temperature control with open window detection				no
				with remote control option				no

¹ There is no entry for fireplaces without water-carrying components.

² Values for annual use efficiency and emissions must be given here for the preferred fuel.

³ Values for annual use efficiency and emissions must be given here for all other suitable fuels.

⁴ Corresponds to partial load heat output as per EN 16510

⁵ Specification in mg/m³ for heated filter method (in compliance with Annexe III, number 4, letter a, section i, point 1) or g/kg for measurement in dilution tunnel (in compliance with Annexe III, number 4, letter a, section i, point 2 and 3.)

⁶ Specification mg/m³ for heated filter method (in compliance with Annexe III, number 4, letter a, section i, point 1) or g/kg for measurement in dilution tunnel (in compliance with Annexe III, number 4, letter a, section i, point 2 and 3.)

⁷ Specifications are made here for the preferred fuel only.

5.1.4 89x49x45-S

Contact details for the manufacturer or their authorised representative

Manufacturer:	Austroflamm GmbH
Contact:	-
Address:	Austroflamm-Platz 1 4631 Krenglbach Austria

Appliance details

Model identification(s):	89x49x45-S
Equivalent models:	-
Test reports:	RRF - 29 12 3073
Applied harmonized standards:	EN 13229
Other standards/technical specifications applied:	-
Indirect heating function:	no
Direct heat output:	12 kW
Indirect heat output ¹ :	-

Properties for operation with the preferred fuel

Space heating annual use efficiency η_s :	70 %
Energy efficiency index (EEI):	106

www.forjas-salvador.com

Particular precautions for assembly, installation or maintenance

Described in the individual sections of the operating manual.

Fuel	Preferred fuel (only one) ² :	Other suitable fuel(s) ³ :	η_s [x%]:	Space heating emissions at nominal heat efficiency (*)				Space heating emissions at minimum heat output ⁴ (*) (**)			
				PM	OGC	CO	NOx	PM	OGC	CO	NOx
				[x] mg/Nm ³ (13% O ₂) ⁵				[x] mg/Nm ³ (13% O ₂) ⁶			
Log, moisture content ≤ 25 %	yes	no	70	26	74	1125	119	-	-	-	-
Compregnated laminated wood, moisture content < 12 %	no	no	-	-	-	-	-	-	-	-	-
Other woody biomass	no	no	-	-	-	-	-	-	-	-	-
Non-woody biomass	no	no	-	-	-	-	-	-	-	-	-
Anthracite and dry steam coal	no	no	-	-	-	-	-	-	-	-	-
Coking coal	no	no	-	-	-	-	-	-	-	-	-
Semi-coke	no	no	-	-	-	-	-	-	-	-	-
Bituminous coal	no	no	-	-	-	-	-	-	-	-	-
Lignite briquettes	no	no	-	-	-	-	-	-	-	-	-
Peat briquettes	no	no	-	-	-	-	-	-	-	-	-
Briquettes made from a mixture of fossil fuels	no	no	-	-	-	-	-	-	-	-	-
Other fossil fuels	no	no	-	-	-	-	-	-	-	-	-
Briquettes made from a mixture of biomass and fossil fuels	no	no	-	-	-	-	-	-	-	-	-
Other mixture of biomass and solid fuels	no	no	-	-	-	-	-	-	-	-	-

(*) PM = dust, OGC = organic gaseous connections, CO = carbon monoxide, NOx = nitrogen oxide

(**) Only required when using correction factors F(2) or F(3).

Properties for exclusive operation with the preferred fuels⁷

Specification	Symbol	Value	Unit	Specification	Symbol	Value	Unit
Heat output				Thermal efficiency (fuel efficiency) (based on the NCV)			
Nominal heat efficiency	P _{nom}	12	kW	thermal efficiency (fuel efficiency) at nominal heat efficiency	$\eta_{th,nom}$	80	%
Minimum heat output (standard value)	P _{min}	-	kW	thermal efficiency (fuel efficiency) at minimum heat output (standard value)	$\eta_{th,min}$	-	%
Auxiliary power consumption				Type of heat output/room temperature control			
At nominal heat efficiency	el _{max}	-	kW	single-stage heat output, no room temperature control			yes
At minimum heat output	el _{min}	-	kW	two or more manually adjustable stages, no room temperature control			no
In standby condition	e _{LSB}	-	kW	room temperature control with mechanical thermostat			no
Pilot flame power requirement				with electronic room temperature control			
Pilot flame power requirement (if present)	P _{pilot}	-	kW	with electronic room temperature control and day-time regulation			no
				with electronic room temperature control and weekday regulation			no
				Other regulation options (Multiple answers possible)			
				room temperature control with presence detection			no
				room temperature control with open window detection			no
				with remote control option			no

¹ There is no entry for fireplaces without water-carrying components.

² Values for annual use efficiency and emissions must be given here for the preferred fuel.

³ Values for annual use efficiency and emissions must be given here for all other suitable fuels.

⁴ Corresponds to partial load heat output as per EN 16510

⁵ Specification in mg/m³ for heated filter method (in compliance with Annexe III, number 4, letter a, section i, point 1) or g/kg for measurement in dilution tunnel (in compliance with Annexe III, number 4, letter a, section i, point 2 and 3.)

⁶ Specification mg/m³ for heated filter method (in compliance with Annexe III, number 4, letter a, section i, point 1) or g/kg for measurement in dilution tunnel (in compliance with Annexe III, number 4, letter a, section i, point 2 and 3.)

⁷ Specifications must be made here for the preferred fuel only.

**5.1.5 89x49x57-S****Contact details for the manufacturer or their authorised representative**

Manufacturer:	Austroflamm GmbH
Contact:	-
Address:	Austroflamm-Platz 1
	4631 Krenglbach
	Austria

Appliance details

Model identification(s):	89x49x57-S
Equivalent models:	-
Test reports:	RRF - 29 12 2658
Applied harmonized standards:	EN 13229
Other standards/technical specifications applied:	-
Indirect heating function:	no
Direct heat output:	12 kW
Indirect heat output ¹ :	-

Properties for operation with the preferred fuel

Space heating annual use efficiency η_s :	70 %
Energy efficiency index (EEI):	106

www.forjas-salvador.com



Particular precautions for assembly, installation or maintenance

Described in the individual sections of the operating manual.

Fuel	Preferred fuel (only one) ² :	Other suitable fuel(s) ³ :	η_s [x%]:	Space heating emissions at nominal heat efficiency (*)				Space heating emissions at minimum heat output ⁴ (*) (**)			
				PM	OGC	CO	NOx	PM	OGC	CO	NOx
				[x] mg/Nm ³ (13% O ₂) ⁵				[x] mg/Nm ³ (13% O ₂) ⁶			
Log, moisture content \leq 25 %	yes	no	70	24	58	1250	114	-	-	-	-
Compregnated laminated wood, moisture content < 12 %	no	no	-	-	-	-	-	-	-	-	-
Other woody biomass	no	no	-	-	-	-	-	-	-	-	-
Non-woody biomass	no	no	-	-	-	-	-	-	-	-	-
Anthracite and dry steam coal	no	no	-	-	-	-	-	-	-	-	-
Coking coal	no	no	-	-	-	-	-	-	-	-	-
Semi-coke	no	no	-	-	-	-	-	-	-	-	-
Bituminous coal	no	no	-	-	-	-	-	-	-	-	-
Lignite briquettes	no	no	-	-	-	-	-	-	-	-	-
Peat briquettes	no	no	-	-	-	-	-	-	-	-	-
Briquettes made from a mixture of fossil fuels	no	no	-	-	-	-	-	-	-	-	-
Other fossil fuels	no	no	-	-	-	-	-	-	-	-	-
Briquettes made from a mixture of biomass and fossil fuels	no	no	-	-	-	-	-	-	-	-	-
Other mixture of biomass and solid fuels	no	no	-	-	-	-	-	-	-	-	-

(*) PM = dust, OGC = organic gaseous connections, CO = carbon monoxide, NOx = nitrogen oxide

(**) Only required when using correction factors F(2) or F(3).

Properties for exclusive operation with the preferred fuels⁷

Specification	Symbol	Value	Unit	Specification	Symbol	Value	Unit
Heat output				Thermal efficiency (fuel efficiency) (based on the NCV)			
Nominal heat efficiency	P _{nom}	12	kW	thermal efficiency (fuel efficiency) at nominal heat efficiency	η _{th,nom}	80	%
Minimum heat output (standard value)	P _{min}	-	kW	thermal efficiency (fuel efficiency) at minimum heat output (standard value)	η _{th,min}	-	%
Auxiliary power consumption				Type of heat output/room temperature control			
At nominal heat efficiency	e _{lmax}	-	kW	single-stage heat output, no room temperature control			yes
At minimum heat output	e _{lmin}	-	kW	two or more manually adjustable stages, no room temperature control			no
In standby condition	e _{lSB}	-	kW	room temperature control with mechanical thermostat			no
Pilot flame power requirement				with electronic room temperature control			
Pilot flame power requirement (if present)	P _{pilot}	-	kW	with electronic room temperature control and day-time regulation			no
				with electronic room temperature control and weekday regulation			no
				Other regulation options (Multiple answers possible)			
				room temperature control with presence detection			no
				room temperature control with open window detection			no
				with remote control option			no

¹ There is no entry for fireplaces without water-carrying components.

² Values for annual use efficiency and emissions must be given here for the preferred fuel.

³ Values for annual use efficiency and emissions must be given here for all other suitable fuels.

⁴ Corresponds to partial load heat output as per EN 16510

⁵ Specification in mg/m³ for heated filter method (in compliance with Annexe III, number 4, letter a, section i, point 1) or g/kg for measurement in dilution tunnel (in compliance with Annexe III, number 4, letter a, section i, point 2 and 3.)

⁶ Specification mg/m³ for heated filter method (in compliance with Annexe III, number 4, letter a, section i, point 1) or g/kg for measurement in dilution tunnel (in compliance with Annexe III, number 4, letter a, section i, point 2 and 3.)

⁷ Specifications must be made here for the preferred fuel only.

5.2 General specifications

Model	63x40x42S	63x40x51S	69x49x57S	89x49x45S	89x49x57S
EN test EN 13229	CE mark				
Nominal heat efficiency in [kW]	8	12	12	12	12
Maximum heat output [kW]	11	16	16	16	16
Max. length of logs	33	33	33	33	33
permissible fuel filling quantity [Kg]	2.35	3.4	3.4	3.4	3.2
Fuel throughput, maximum [kg/h]	2.3	3.58	3.72	2.34	2.13
Cross-section, convection outlet [cm ²]	700	700	1230	700	1200
Cross-section, convection inlet [cm ²]	700	700	705	700	1200
Power output via pane [%]	37	37	35	32	41

Emissions values					
	63x40x42S	63x40x51S	69x49x57S	89x49x45S	89x49x57S
CO [mg/Nm ³]	≤1250	≤1250	≤1250	≤1250	≤1250
Dust based on 13% O ₂	≤40	≤40	≤40	≤40	≤40
OGC [mg/MJ]	≤50	≤50	≤50	≤50	≤50
NO _x based on 13% O ₂ [mg/m ³]	≤150	≤150	≤150	≤150	≤150
Efficiency [%]	≥80	≥80	≥80	≥80	≥80
Flue gas temperature [°C]	230	283	260	307	297
***)					
Flue gas mass flow [g/s]	7.65	12.0	12.42	10	10.5
Minimum feed pressure at nominal heat output [Pa]	12	12	12	12	12

Distances from fireplace insert					
	63x40x42S	63x40x51S	69x49x57S	89x49x45S	89x49x57S
Distances from fireplace insert to heating chamber wall [cm]	6				

Specifications for fire- and heat protection (specifications in mm, Promasil 950 KS) Insulation layer thicknesses					
	63x40x42S	63x40x51S	69x49x57S	89x49x45S	89x49x57S
Insulation layer thicknesses at installation base [mm]	-	-	-	30	30
Insulation layer thicknesses, lateral / rear [mm]	100/120	120	100/120	120	120
Insulation layer thicknesses at ceiling [mm]	in accordance with normal regional installation standards (e.g. TR OL, FeuVo)				
b: Safety distance, lateral [mm]	1100	800	500	1200	1200
a: Safety distance, front [mm]	1100	900	1700	1200	1200

Combustion air					
	63x40x42S	63x40x51S	69x49x57S	89x49x45S	89x49x57S
Outside air connection [Ø mm]	150	150	150	150	150
Combustion air requirement [m ³ /h]	44	34	34.6	48	48



Use for special design	63x40x42S	63x40x51S	69x49x57S	89x49x45S	89x49x57S
Hypocaust heating**)	Suitable subject to technical rules				

*) under examination

**) The Austroflamm appliances marked with "suitable subject to technical rules" are suitable for operation in closed systems (hypocausts)

***) at the device connection at nominal heat efficiency

*) under examination

**) The Austroflamm appliances marked with "suitable subject to technical rules" are suitable for operation in closed systems (hypocausts)

***) at the device connection at nominal heat efficiency

The design of the hypocaust must ensure the transport of heat and the even distribution of heat within the cladding so that no part of the heating chamber can be overheated.

The size of the heat-dispensing cladding surfaces must be matched to the heat generator.

The necessary insulation thicknesses specified in the technical data for the protection of building surfaces adjacent to the heat-producing appliance have been determined with open air grilles in continuous operation and must therefore be supplemented by suitable measures (e.g. rear ventilation).

The closed system must be calculated and designed in accordance with the technical rules of the stove- and air heating constructors trade association.

When setting up a closed system with Austroflamm fireplace inserts with sliding door, the temperature resistance of the cable drum is 250 °C. This maximum permissible ambient temperature must be observed! If the hypocaust is built to the specifications of the TR OL, this material temperature should never be reached. A rear ventilation of these components may need to be planned.

5.3 Data for the chimney/flue dimensioning

Fireplace inserts with self-closing firebox doors.

Description: Fireplace insert EN 13229 - A1 / A. For values see Technical data.

TIP

When the draft is too great, the draft must be limited. Ensuring the correct draft is a matter for the stove/tiled stove builder.

TIP

For a chimney draft above 18 Pa it is urgently recommended that a throttle valve (available as an accessory) be incorporated into the connecting piece!

NOTICE

Operation allowed only with closed firebox.



Minimum cross-sections of chimney / combustion air pipe

Appliance	Minimum chimney cross-section	Minimum exterior air cross-section (for closed operation)	
		Up to 3 m length - max. 1 elbow	Up to 6 m length - max. 2 elbows
63x40x42 S	Ø 150 mm	175cm ²	255cm ²
63x40x51 S	150 / 150 mm	Pipe Ø 150 mm	Pipe Ø 180 mm
69x49x57 S	Ø 180 mm	175cm ²	2555cm ²
89x49x S	180 / 180 mm	Pipe Ø 150 mm	Pipe Ø 180 mm

The following points are to be observed for exterior air conduits:

- do not create a bend, as the cross-section will be reduced
- keep cross-section constant
- The free air passage at the air grille must not be less than the actual cross-section of the recommended external air duct
- there must be no negative pressure (suction) at the point of the air duct intake, even in unfavourable wind conditions

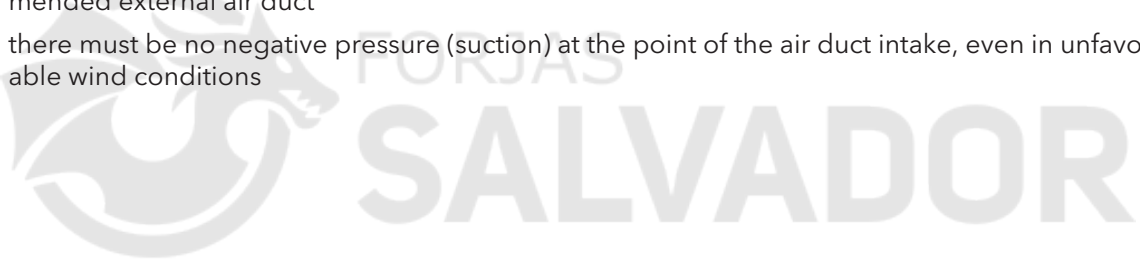

www.forjas-salvador.com

6 Transport and storage

6.1 Transportation



Fig. 2: Crate

Immediately checked the goods delivered for completeness and damage in transit.

Before installing the fireplace insert, check that all movable parts are working. Any defects before the installation of the fireplace insert must be reported.

Transport is with a crate. Use a lifting truck or forklift to transport the crate including the fireplace insert.

Remove the crate and dispose of it appropriately.

6.1.1 Transport security

Before the fireplace insert is clad, it is vital that the transport lock is removed and the functioning of the sliding doors checked. Depending on the model, the counterweight of the sliding door is secured on the outside left or on both sides outside or on the rear panel of the appliance with a coloured screw and a shim.

NOTICE

It is vital that the transport lock screws are removed before the appliance is installed!

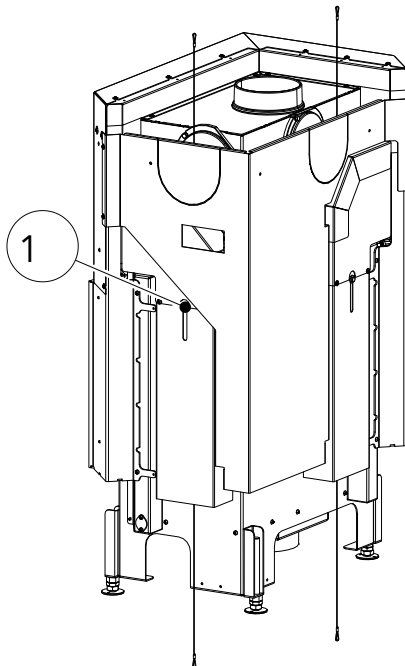

Fig. 3: Removing the transport lock

The counterweight of the sliding door is secured on each device side with a screw.

Should the appliance have to be transported again, then it is vital to reinstall this transport lock screw so that the weight is safely secured.

- 1) Remove left or right transport lock (1) from the fireplace insert.

6.2 Storage

The fireplace insert must be stored in a dry room/warehouse. Protect against dirt, heat and moisture.

The following illustrations are attached to the crate and must be observed:



- Fragile - always place upright - protect against moisture and store dry.



- Remove and dispose of packing material in an environmentally friendly manner.



- The crate can be disposed of in the separate collection for packaging. Local disposal regulations must be observed.



FORJAS
SALVADOR

www.forjas-salvador.com

7 Requirements at the installation location

7.1 Requirements at the room of installation

Fireplaces must not be set up in:

- spaces in which the required combustion air supply is not guaranteed.
- spaces which are generally accessible, especially emergency exits staircases in residential building with no more than 2 apartments are not included in general accessible spaces.
- spaces in which easily flammable or potentially explosive substances or mixtures are processed, stored or manufactured.
- spaces, apartments or units from which air is extracted with the aid of ventilators, such as ventilation- or hot-air heating installations, extractor hoods or exhaust air tumble dryers. Unless the safe function of the fireplace insert is ensured:

This is ensured if:

- the systems only circulate air within a space.
- the systems have safety features which autonomously and reliably prevent negative pressure in the installation space.
- simultaneous operation of the fireplace and the air-extracting system is prevented by safety features.
- the flue gas routing is monitored by a particular piece of safety equipment.
- no negative pressure greater than 0.04 mbar occurs overall via the combustion air flow of the fireplace insert and the volume flows of the ventilation systems in the installation room and rooms connected via the ventilation network. This must also be guaranteed when easily accessible ventilation system control equipment is adjusted or removed.

TIP

When operating a controlled living room ventilation system, the use of a DIBT-tested heat-producing appliance connected to a balanced flue is recommended.

7.2 Installing the fireplace insert

Observe the guidelines on fire safety, such as thermal insulation and air grille sizes.

DANGER

Fire hazard

Operating your Austroflamm fireplace insert with too high a fuel feed will create a risk of the chimney and adjacent components or furniture overheating.

7.3 Combustion air supply

For heat-producing appliances that draw their combustion air from the installation room an adequate supply of combustion air into the room must be provided. Other heat-producing appliances or ventilation facilities in the installation room or combustion air network may make a separate combustion air supply from outside necessary.

Air suction systems (e.g. ventilation system, cooker hood, etc.) that are operated together with the heat-producing appliance in the same room air network may disrupt the combustion air supply and possibly require additional safety measures under the heating regulations.

Combustion air supply via direct duct (balanced flue operation)

The combustion air supply can also be fed via a direct duct from outside to the fireplace insert. For this purpose the combustion air must be safely routed from the house's external air connection directly to the combustion air trunking.

The duct cross-section can be determined with the help of the pressure-volume diagram (see technical rules of the Stove- and Air Heating Constructors Association). See Section "Min. cross-section of chimney combustion air duct". This method of connection is generally recommended.

Combustion air supply from the room (balanced flue operation)

The Austroflamm fireplace insert obtains its combustion air exclusively via the direct combustion air trunking directly from the installation room.

For all the models described in this manual you will find the combustion air trunking on the underside of the combustion chamber. For this reason a faultlessly working combustion air feed into the heating chamber must be ensured. This absolutely requires the correct dimensioning of the circulating air cross-sections, in addition to the necessary combustion air cross-section. The correct positioning of the corresponding openings into the heating chamber is very important.

Non-compliance can cause a lack of air during combustion.

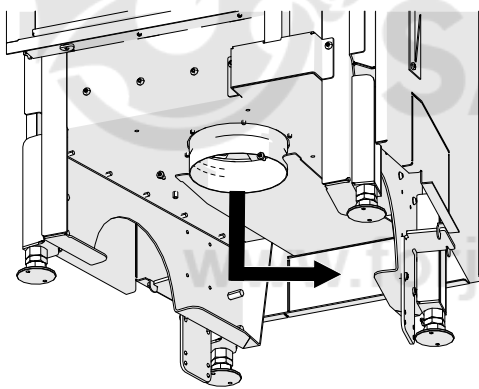

The combustion air trunking must always be connected, as otherwise no combustion air is routed into the firebox.

Fig. 4: Combustion air trunking

7.4 Combustion air duct

Combustion air ducts must be made of dimensionally stable construction materials, sealed and accessible for inspection and cleaning. Consideration must be given to possible condensation formation from falling below the dew point and prevented by suitable insulation.

For combustion air ducts in buildings with more than 2 full storeys and combustion air ducts which bridge firewalls, the ducts must be executed so that fire and smoke cannot be transmitted into other storeys or fire sections (see state building regulations).

7.5 Chimney requirements

Before set-up or installation of the Austroflamm fireplace insert, the chimney must be checked for its size and quality under the existing local regulations (respectively state building regulations, heating regulations and DIN 18160, Part 1). The mathematical proof of the adequate function of the chimney must be provided in accordance with EN 13384. Consideration must be given when making the calculation that the substantially greater quantity of air can also be safely removed when the door is open (stoking up fuel).

The operation of your Austroflamm fireplace insert is primarily dependent upon the faultless working of the chimney.

TIP

Care must be taken that all openings, such as openings for cleaning, of fireplace being used are closed during operation.



7.6 Multiple occupancy

All Austroflamm fireplace inserts in this manual have been checked and approved under DIN EN 13229 with self-closing and locking door (designated BA1). Appliances intended to operate BA1 can be connected to a multiple-occupied chimney (if multiple occupancy is possible). The calculation is made according to DIN EN 13384 Part 2.

NOTICE

Multiple occupancy of the chimney is not allowed with balanced flue operation!

7.7 Flue pipe connecting pieces

The connecting piece must be selected in accordance with DIN EN 13384.

The connection between fireplace insert and heat recovery surface or to the chimney must be made using steel flue pipes with a minimum wall thickness of 2 mm, or flue pipes made of austenitic, non-rusting steel with a minimum wall thickness of 1 mm.

The connecting piece must be connected directly to the chimney.

The connecting piece inside the cladding must be covered with at least 3 cm thick, dimensionally stable, non-flammable insulation material of Class A1 as per DIN 4102, as described in the section Thermal insulation layers and materials.

This does not apply to connecting pieces that are intended for heating convection air and for which fire hazard is otherwise excluded.

www.forjas-salvador.com



8 Fuel material/-quantity

8.1 Fuel material

Wood

Many of our native types of wood can, after being appropriately dried, be burnt CO₂-neutral in heat-producing appliances. Wood stands out because it grows again, can be sustainably harvested, requires little or no extra external energy to be invested in the fuel, and has a short journey from the producer to the consumer, which provides an optimal climate balance.

The most common types of wood to use in the stove are beech, yoke elm, birch, larch, spruce and pine. The most important criterion for burning in a heat-producing appliance is that the fuel has been sufficiently dried through. For this purpose the prepared pieces of log should be stored for at least two years. The legislator stipulates a maximum water content of 20%. That is still however a lot of water sitting in the capillaries of the wood. A piece of firewood only becomes good when its water content comes to a maximum of 12 to 13%. The differences in combustion behaviour are striking and clearly detectable even by the layman.

Types of wood other than the ones referred to above are also suitable for burning. However each heat-producing appliance should be checked for how their use affects combustion behaviour. Oak for example burns with a rather shorter flame and more embers. Oakwood catches fire with greater difficulty, and due to hardness of the wood it is not split as well (small) as other types of wood, which again has a negative effect on combustion behaviour. It is however a good energy source, and, correctly processed, also suitable as firewood.

Softwoods (fir, pine, spruce) should if possible be mixed with hardwood. Softwoods have a higher proportion of tannin, which leads to more deposits in the heat-producing appliance, the connecting pipes and the chimney. If only softwood is burnt, this can lead more quickly to a build-up of shining soot. Mixing with hardwood (for example, beechwood) reduces this effect.

The size of your heat-producing appliance's combustion chamber will dictate whether your firewood is 25cm, 33cm or 50cm in length. 50cm pieces of log should preferably dry for somewhat longer (laid down for three years or more), because wood is dried out mainly by the leakage of water from the capillaries - and that simply takes time. And the path from inside to outside in a 50cm-long piece of log is twice as long as in a 25cm-long piece of log. The important thing is that the wood is well split. This means that the circumference of a piece of log (once all sides are measured around the cutting point) must be a maximum of 15-25cm. Pieces of wood cut to this size dry more easily - above all, however, they give the fire (the temperature) a greater attack area and thus make it easier to evolve gas and thus to burn. Also the quantity of fuel can be better measured out. Thanks to their outstanding levels of efficiency, modern heat-producing appliances require just a fraction of the amount of wood of earlier stoves. Here smaller pieces of log can be placed according to the manufacturer's specifications - large pieces of log often exceed the maximum specified quantity with just a single piece.

Not everyone has a hygrometer at home for determining the water content in wood, particularly when good reliable units cost several hundred euros. However you can make a good estimate of how suitable your fuel is by carefully observing combustion behaviour. A "good" wood fire will only smoke briefly in the ignition phase, hardly at all after that. It will burn with a light (yellow to orange-coloured) long flame. Little residue will occur in the combustion chamber, most of it disappearing again when the fire is fully developed. Another good criterion for assessing whether a piece of log is suitable for combustion is its weight. Most manufacturers also specify the amount to be laid in kg/weight. Example: a piece of beechwood 33cm in length with a circumference of approx. 20cm weighs approx. 1kg when it is suitable (dry enough) for burning. Therefore 25cm in length gives approx. 750 grammes, and 50 cm in length approx. 1.5kg.

Please observe at all times the maximum specified amount to be laid, even when putting on more wood! Otherwise your fire will not provide the desired efficiency - but above all considerable damage may be caused to your appliance, to gaskets and material and to the flue gas duct.

The wood may only be burnt untreated. NEVER burn treated woods, not even wood processed with natural substances or organic glazes. Wood waste does not belong in the stove!

Wood briquettes

Many people like wood briquettes as a fuel because they require less storage space than wood, can be stocked or sold in small quantities and - at least at first glance - make less work than wood. Within the scope of production, the quality of briquettes is consistent. Wood briquettes do not need to be stored for a long time to be dried out. Due to the raw material (unrefined chips) and the production process they have an already defined residual moisture.

If wood briquettes are designated as a suitable fuel, then this still only applies to this fuel, NOT for coal-, paper-, bark- or other pressed items, such as pellets.

In spite of various standardizations and many advertising promises, there are also considerable differences in quality in wood briquettes. But even with good fuel quality, combustion behaviour is different from that of unrefined log. And not every wood briquette burns equally well in every stove. Before you decide on a particular variety and perhaps even store this up in larger quantities, you should extensively test the wood briquettes under various draft conditions. Most suppliers keep "test packages" for this purpose that can be purchased at preferential prices to test out and compare with one another the various types offered.

TIP

When burning wood briquettes, the maximum quantity specified in these instructions must also be observed. The quantity must not be exceeded.

As the wood is pressed and thus has little spatial volume for the same weight, modern heat-producing appliances with a low placement quantity often have "little fire heaps" occur, leading one to wonder whether a fire can burn at all with so little fuel. Nevertheless you must never exceed the maximum placement, because that would cause damage. Many wood briquettes change during the temperature increase when burning, by "opening up". This should not worry you as it is normal. When inserting wood briquettes make sure that this expansion as far as possible does not press not in the direction of the window, as otherwise this will get very dirty.

In principle you should not insert wood briquettes as one piece, but rather break them at the layer thicknesses, which are usually visible in slices, and place smaller pieces in the combustion chamber, not in an interlocking manner, but randomly. This way you will ensure that the combustion air reaches more burning material and flows around it better. Wood briquettes require a stronger air current, an expert eye and perhaps a bit more patience, until you get the knack of it. Since less volume is available (although the same mass, it takes less space up), the fire is generally smaller and does not burn so high and vivaciously as when burning log. When wood briquettes alone are burnt, this therefore generally leads to haziness in the combustion chamber, as well as on the stove window. Not all areas of the combustion chamber have the same temperature applied to them as when unrefined wood is burnt, which is why these deposits occur. It may be that with one variety of wood briquettes more deposits occur, whereas with another variety none at all. This suggests trying out various varieties to determine the suitable fuel for your heat-producing appliance. If you would really like to use wood briquettes, but don't get on quite well with them, then it may also help to mix the fuel. That means: Burn wood briquettes and unrefined log in the mixture ratio that achieves a good burning result for your heat-producing appliance.

Wood briquettes must also be stored dry. In general it can be said that pressed items with a hole in the middle usually burn better. Soft wood briquettes are to be preferred and are often more suitable than hard wood briquettes.

Approved fuel

Dry, properly stored, unrefined log (preferably hard wood) is permitted as fuel for our hybrid stoves

Round wood must be split at least once so that it lights better. The diameter of the split piece of wood must not exceed 7 cm.

Fuel

Only burn the recommended fuel.

Explosive substances

It is strictly forbidden to burn or introduce highly flammable or explosive substances (empty aerosols and the like) into the firebox or to store them in the immediate vicinity of your fireplace insert. Risk of explosion!

8.2 Fuel quantity

NOTICE

To avoid damage you must **NEVER** operate your fireplace insert a greater quantity of fuel than that specified in this manual!

For this purpose, please observe the section Technical data.

www.forjas-salvador.com

9 Installation instructions

NOTICE

Damage to the appliance

The fireplace insert must not have any connection to the housing (minimum gap width 3 mm), as otherwise damage may be caused to the appliance.

9.1 Set-up in front of or next to a wall to be protected

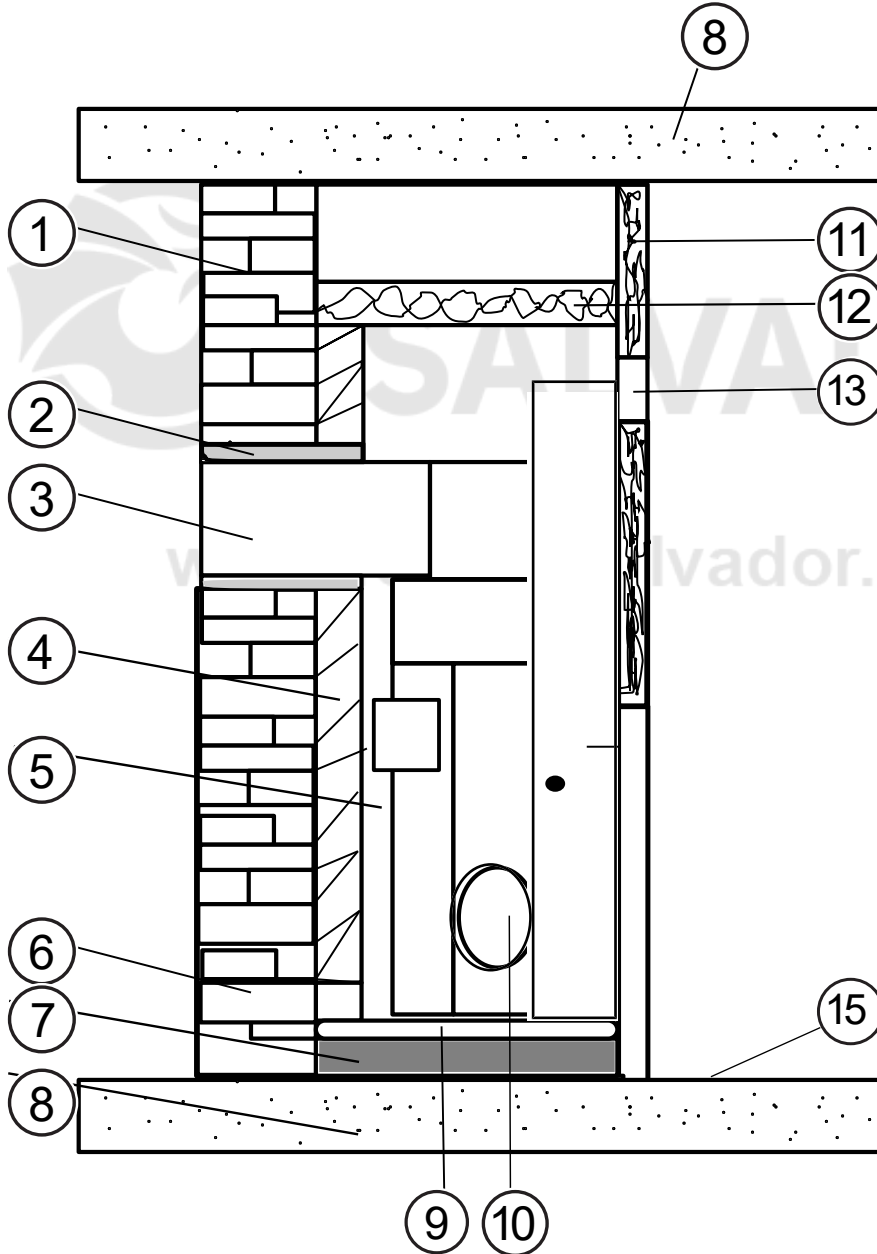

Fig. 5: Set-up in front of/next to a wall to be protected

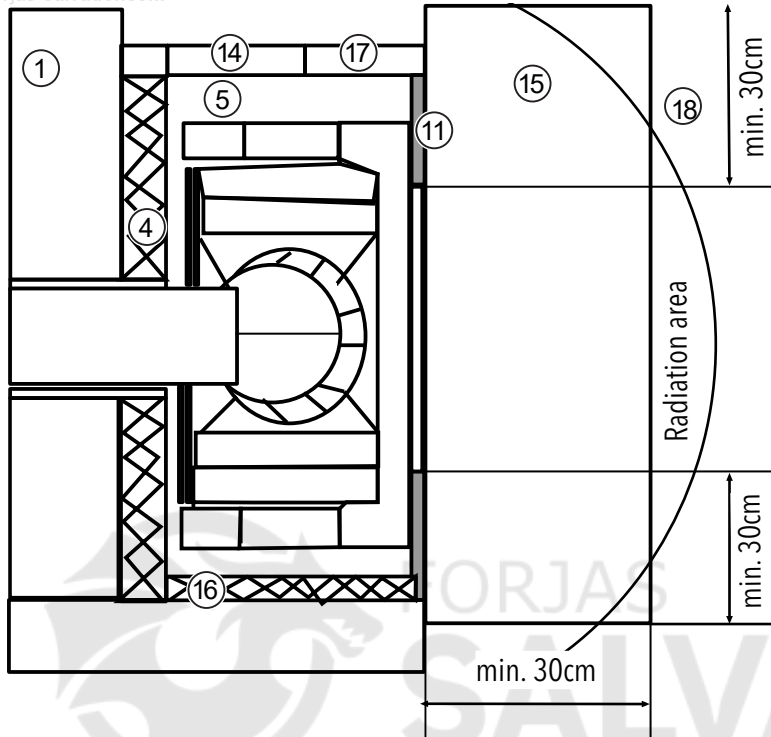

Fig. 6: Set-up in front of/next to a wall to be protected

1	Wall / building wall	2	Thermal insulation layer (flue pipe)
3	Connector	4	Thermal insulation layer (rear panel)
5	Convection room	6	Exterior air intake
7	Concrete slab at least 6 cm (only when being set up on a ceiling to be protected)	8	Ceiling
9	Thermal insulation layer (concrete)	10	Combustion air trunking
11	Cladding (facing the room)	12	Thermal insulation layer (ceiling)
13	Inlet air outlet grille	14	Circulation air intake grille
15	Shielding floor protection made of non-flammable materials	16	Thermal insulation layer (side wall)
17	Cladding (facing the room)	18	80 cm radiation area
19	Convection air cladding		

Side and rear thermal insulation layers

The building wall to be protected (1) must be protected with a insulation layer (16). The thickness of the insulation layer can be found in the Technical Data.

The cladding (11) must likewise be protected with an insulation layer. The cladding does not need to be protected if the open stove is designed in such a way that the free surfaces of the cladding and the surfaces of the niches for fuel storage can heat up to a maximum of 85 °C. For surfaces made of mineral construction materials, e.g. stove tiles, excluding surfaces on which objects may be placed, the value of 120 °C instead of the value of 85 °C. The increase of the maximum permissible temperature from 85 °C to 120 °C applies only to the more strongly inclined or vertical surfaces of the cladding made of mineral construction materials. This therefore allows the cladding to be developed as a heated tiled wall or similar.

9.2 Convection air cladding

NOTICE

When using CV cladding, please observe the national regulations in respect of individual room fireplaces and the measurement requirement in the case of whole-home heating.

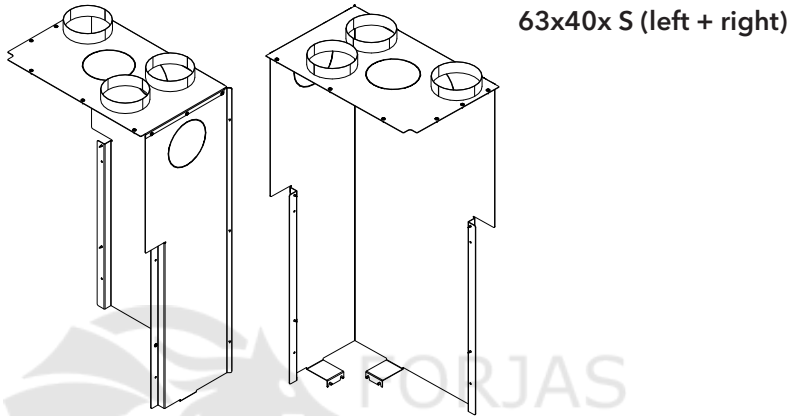

Fig. 7: KV cladding 63x40x S left / right

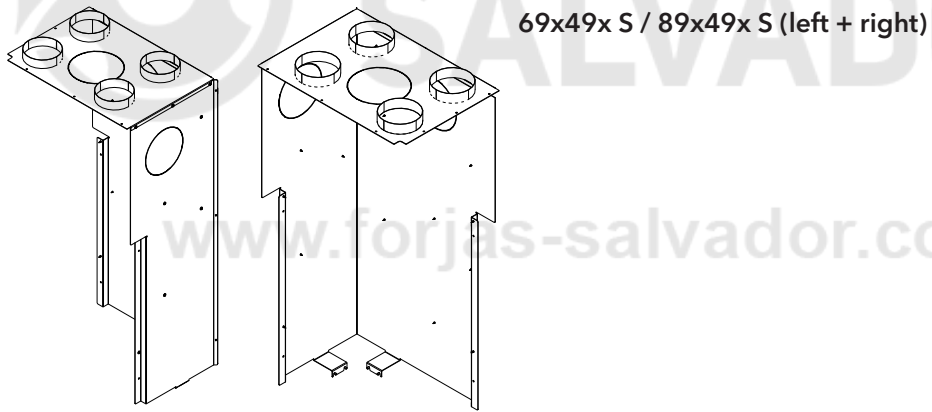
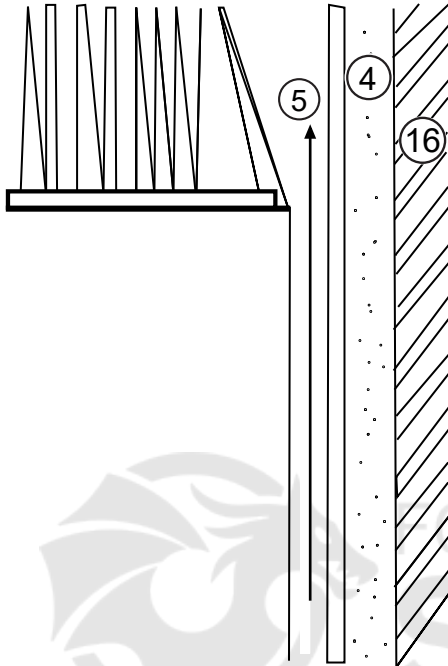

Fig. 8: KV cladding 69x49x - 89x49x left/right

9.3 Convection space



- If the convection cladding (appliance part) is not used, a convection space of at least 6 cm depth between fireplace insert (4) and insulation layer (16) to the rear and on both sides must be allowed for.
- The convection space (5) must be heat-insulated to all areas that are not heat-emitting claddings.
- The walls, the floor and the ceiling of the heating chamber must be clean and resistant to abrasion (see technical rules of the stove- and air heating constructors association). Therefore the insulation layer, if it is not calcium silicate slabs, must be protected with an abrasion-resistant material (heat shield/heating chamber plate or similar).

4	Convection space between fireplace insert and insulation layer
5	Convection space
16	Insulation layer

Fig. 9: Convection space

Convection air duct with convection cladding

All convection air ducts must be made of dimensionally stable, non-flammable construction materials. The warm air pipes must be fixed firmly to the warm air-/(supply) collar of the convection cladding and the grilles (optimally with collar plate).

9.4 Convection conduction

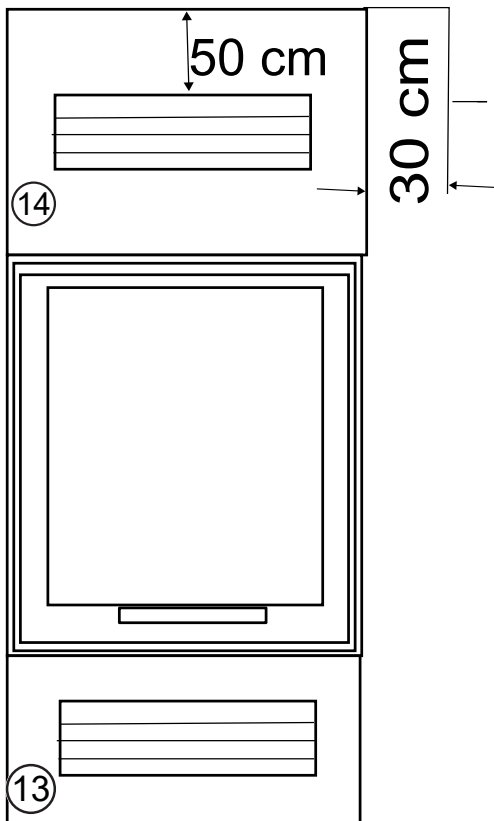

- You can find the cross-section for the air outlet (14) and air inlet (13) in the technical catalogue, the product data sheet from the homepage or the Technical Data section in this manual.
- Above at least 200 cm², air inlet and air outlet must not be lockable.
- There must be no flammable construction materials, e.g. wooden ceiling, and no furniture within a range of 30 cm next to and 50 cm above the air outlets (14).

13	Air inlet
14	Air outlet

Fig. 10: Convection conduction

9.5 Fireplace system without air grille (hypocaust)

The convection air circulates within the closed cladding. The heat is emitted via radiation above the cladding.

9.6 Protecting the installation base

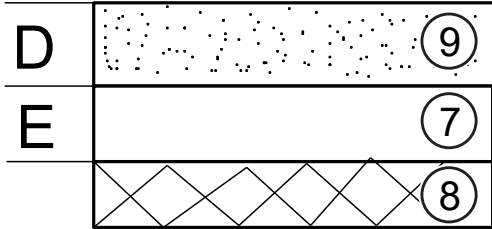

Fig. 11: Protecting the installation base

Installation bases (8) with flammable construction materials with a concrete slab (7) at least 6 cm thick (dimension E), which must be reinforced above installation bases without adequate lateral distribution, and above that by a thermal insulation layer (9) at least 5 cm (dimension D).

Bearing concrete- or reinforced concrete floors (8) must be protected by a thermal insulation layer at least 5 cm thick (9).

7	Concrete slab
8	Installation base (concrete or reinforced concrete)
9	Thermal insulation layer

At least 2 cm for 71x51/57 S3 models.

9.7 Expansion joints

There must be no direct connection between fireplace insert and cladding (11). Therefore all points of contact between appliance and cladding must be separated with a sealing tape (glass fibre tape). Therefore neither must the frame (23) rest on the appliance or be screwed, bolted or welded to it.

9.8 Cladding

The room-facing cladding (11) must be made of construction material class A1 non-flammable materials. These are e.g. wall tiles, wall bricks, stove tiles, metal, plaster on lathing.

9.9 Fireplace aprons

The fireplace apron must not have any direct connection to the fireplace insert. It must be set up to be self-supporting. The manufacturer offers various frames (23) for this purpose.

9.10 Ornamental beam

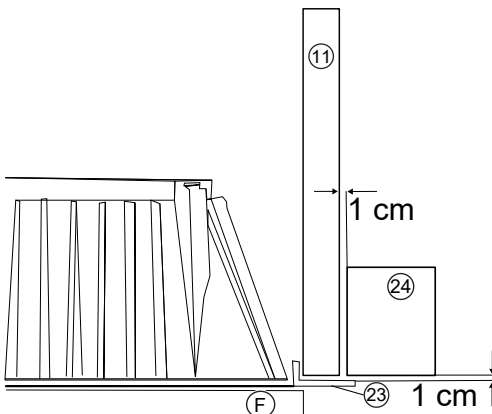

Fig. 12: Ornamental beam

The ornamental beams (24) are permissible at a distance of at least 1 cm in front of the cladding (11) and frame (23) of the open fireplace insert if:

- the ornamental beam is not a component of the building.
- the clearance spaces to the cladding are so open that no accumulation of heat can occur.
- the ornamental beam is not within the radiation area of the open fireplace insert.

11	Cladding
23	Frame
24	Ornamental beam
F	Expansion joint

9.11 Ceiling above the fireplace insert

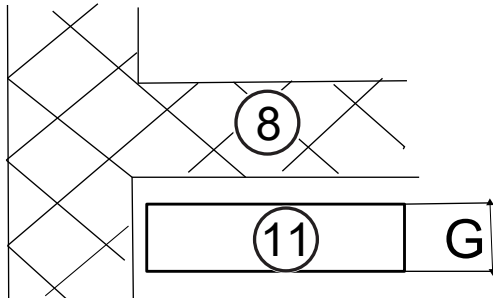

Fig. 13: Ceiling above fireplace insert

If the cavity above the fireplace insert reaches as far as the room ceiling (8), then the latter must be protected if:

- it consists of flammable components
- it serves as a bearing component

The thermal insulation layer (11) (dimension G) must be executed in compliance with the normal regional installation standards.

8	Room ceiling
11	Heat insulation layer

9.12 Floor in front of the fireplace insert

The floor in front of the fireplace insert must be made of flammable material. Minimum dimensions of this non-flammable area: forward at least 50 cm, to the sides at least 30 cm.

9.13 Fire protection

Fire protection within the radiation area

The minimum clearance (see Technical Data) from the firebox opening to components made of flammable construction materials or flammable components as well as furniture must be observed in front and at the side. Half the distance is sufficient for an arrangement of radiation protection ventilated on both sides.

Fire protection outside the radiation area

From the outer surfaces of the cladding of the open fireplace insert a distance of at least 5 cm must be maintained from components made of flammable construction materials or flammable components and from built-in furniture. The clearance space must be so open to the air current that an accumulation of heat cannot occur. Components which only cover small areas of the cladding of the open fireplace insert (such as floors, butt-joined wall cladding and insulation layers on ceilings and walls) can be brought up to the cladding without any gap.

9.14 Heat insulation layers and materials

Insulation layers must be made of heat insulating boards of construction material class A1 as per DIN 4102 Part 1 with a maximum application temperature of at least 700 °C and a bulk density of more than 80 kg/m³. The insulation material must be marked with the appropriate insulation material code number as per AGI-Q 132. Only the insulation materials which are listed in the following table may be used. If other insulation materials are used for the insulation layers, these must have an appropriate DIBT approval (German Institute for Structural Engineering Berlin) (e.g.: Promat calcium silicate thermal insulating board "Promasil 950 KS", Wolfshöher thermal insulating board "Prowolf", Wolfshöher thermal insulating board "Vermilite 2000", Thermax thermal insulating board "Thermax SN 400"). For building external walls and ceilings to be protected that have a U-value below 0.4 W/m², additional rear ventilation (see technical rules of the Stove- and Air Heating Constructors Association) will be necessary.

Insulation materials		Delivery		Insulation capacity		Upper maximum application temperature		Bulk density	
Group	Type	Group	Type	Group	Type	Group	In °C	Group	kg/m ³
10	Mineral fibre	1	Channels	1	Mats, size 1	20	-200	2	20
11	Glass fibre	2	Fibres, loose	2	Mats, size 2	25	-250	3	30
12	Stone fibre	3	Fibres, granulate			30	-300	4	40
13	Slag fibre	4	Felts			35	-350	5	50
		5	Laminated mat			40	-400	6	60
		6	Mats			45	-450	7	70
		7	Slabs			50	-500	8	80
		8	Shells			55	-550	9	90
		9	Segments			60	-600	10	100
		10	braids	10	Shells size1	65	-650	11	110
				11	Shells size2	72	-700	12	120
						75	-750	13	130
						80	-800	14	140
						85	-850	15	150
				20	Slabs size 1	90	-900	16	160
				21	Slabs size 2			17	170
								18	180
								19	190
								20	200
		99	Other	99	Specific-ation	99	*	99	*

*divergent test conditions

Thermal insulation layers must be seamless and overlapping.

If thermal insulation layers within the convection area are used for all fireplace inserts without convection cladding made of mineral wool, these must also be clad in an abrasive-resistant and non-reflective manner (e.g.: with black plate or sheet steel or galvanised sheet iron).

It is vital to ensure that the thermal insulation materials have sufficient heat resistance (min. 700 °C). Otherwise odours may form in the firing operation.

Side and rear thermal insulation layers

The building wall to be protected (1) must be protected with a insulation layer (16). The thickness of the insulation layer can be found in the Technical Data.

The cladding (11) must likewise be protected with an insulation layer. The cladding does not need to be protected if the open stove is designed in such a way that the free surfaces of the cladding and the surfaces of the niches for fuel storage can heat up to a maximum of 85 °C. For surfaces made of mineral construction materials, e.g. stove tiles, excluding surfaces on which objects may be placed, the value of 120 °C instead of the value of 85 °C. The increase of the maximum permissible temperature from 85 °C to 120 °C applies only to the more strongly inclined or vertical surfaces of the cladding made of mineral construction materials. This therefore allows the cladding to be developed as a heated tiled wall or similar.

9.15 Electric cable runs

There must be no electric cable runs in walls and ceilings within the installation area of the fireplace insert.

9.16 Balanced flue-tested fireplace inserts

Flue pipe connection

- The flue pipe connection must be permanently tight
- The flue pipes used must be DIN EN 1856-2 tested.

Combustion air connection:

- The combustion air connection must be sufficiently tight
- Aluminium flexible pipes must not be deformed



www.forjas-salvador.com

10 Connection to ceramic flues

The specifications given in advance in respect of mounting instructions and installation regulations remain valid (see distances, thermal insulation, exhaust pipe connection).

The appliances are particularly suitable for installation with ceramic flues. However the faultless working of the heating system is only guaranteed if the following points are observed:

- Calculation of the ceramic flue
- Use of suitable Materials
- Compliance with maximum lengths of flue
- Installation of a direct- or heating flue
- Compliance with the necessary free area of the air grilles

The calculation of the ceramic flue must be made in compliance with the specified maximum flue lengths and according to the technical rules of the Stove- and Air Heating Constructors Association and valid designs.

Characteristics for calculating the flue dimensions

Appliance type	Exhaust gas mass flow [mg/s]	Flue gas temperature at appliance collar [°C]	Req'd Feed pressure at collar [Pa]
63x40x42 S 63x40x51 S	7.65/12.0	230/283	12
69x49x57 S	12.42	260	12
89x49x45 S 89x49x57 S	10/10.5	307/297	12

Maximum length of chamotte ceramic flues

The flue gas temperatures at the appliance collar are average temperatures over the duration of the combustion.

Appliance type	Flue length [m]	Feed pressure at collar [Pa]	Flue gas temperature downstream of the flues [°C]
63x40x42 S 63x40x51 S	4	12	190
69x49x57 S	4	12	190
89x49x45 S 89x49x57 S	4	12	190

The flue is constructed of refractory mineral materials. When setting up, attention must be paid to processing that is impervious to heating gases. The ceramic flue support must be load-bearing and heat-resistant. The installation base on which the heat exchanger is to be set up must be heat insulated in analogy to the manner described in the section on Protection of the set up area.

The flue pipe connection must be connected gas-tight to the ceramic flue by means of plug-in steel tubes. The connection of the pipes to the ceramic flue is preferably to be made with a premanufactured connection block made of chamotte.

TIP

The steel tube/chamotte transition must be separate (expansion) and tight. The connecting pipes do not need to be thermally insulated.

TIP

Make the operator of the stove aware that the system with a downstream heat recovery surface must only be operated with the door closed!

10.1 Stove with ceramic flue

Example using KMS system

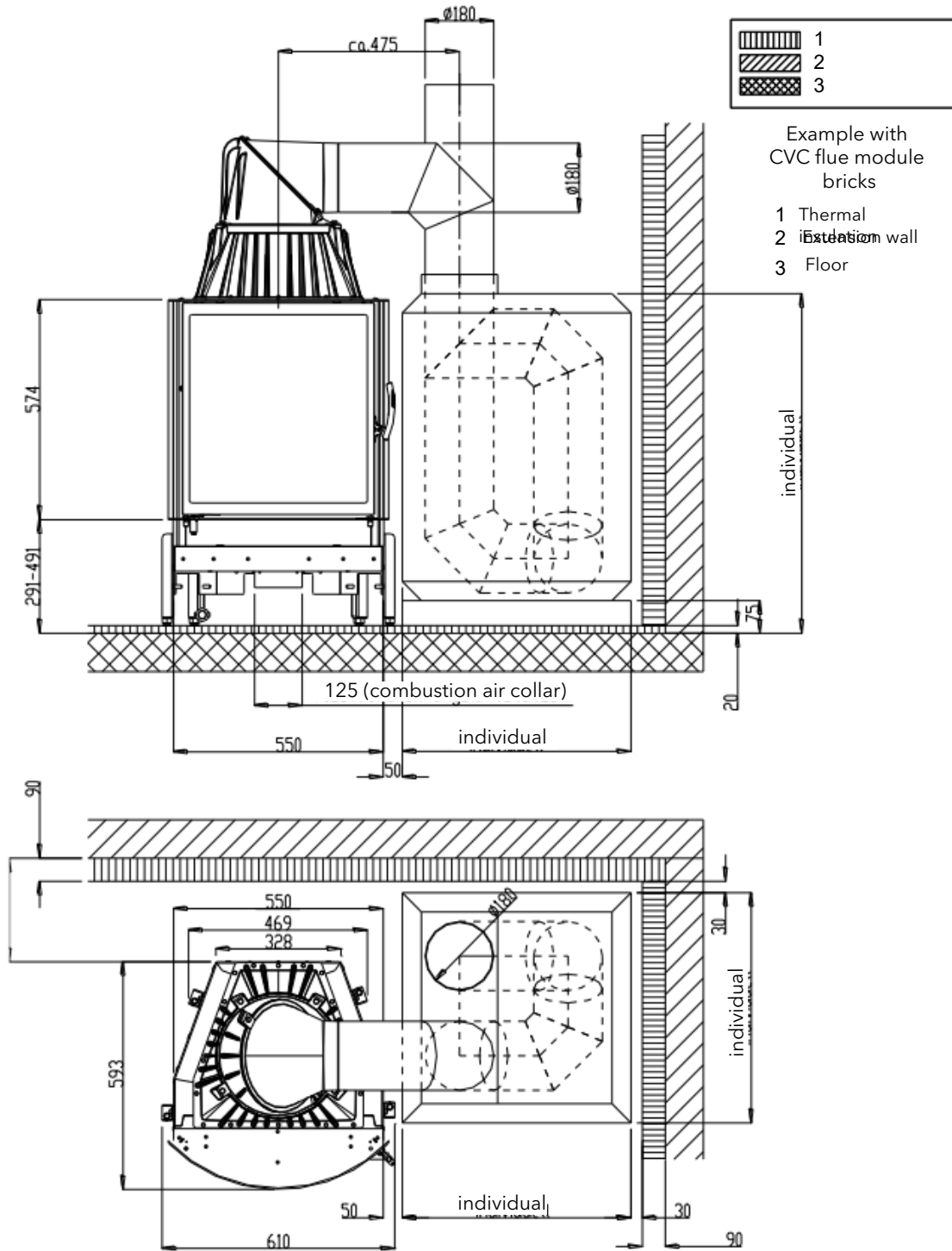

Fig. 14: Connection to ceramic flue heat exchanger

10.2 Connection to heat recovery surfaces

The specifications given in advance in respect of mounting instructions and installation regulations remain valid (see distances, thermal insulation, exhaust pipe connection).

The metallic heat exchanger can be placed to the left or right side or behind the fireplace insert.

For details, please see the following dimensioned sketch.

The base of the heat exchanger must be stable and heat resistant. The installation base on which the heat exchanger is to be set up must be heat insulated in analogy to the manner described in the section Protecting the installation floor.

Access to the cleaning openings on the heat exchanger must be ensured.

- General condition: The joining pieces from the fireplace insert and to the chimney must not longer in total than 1 m.

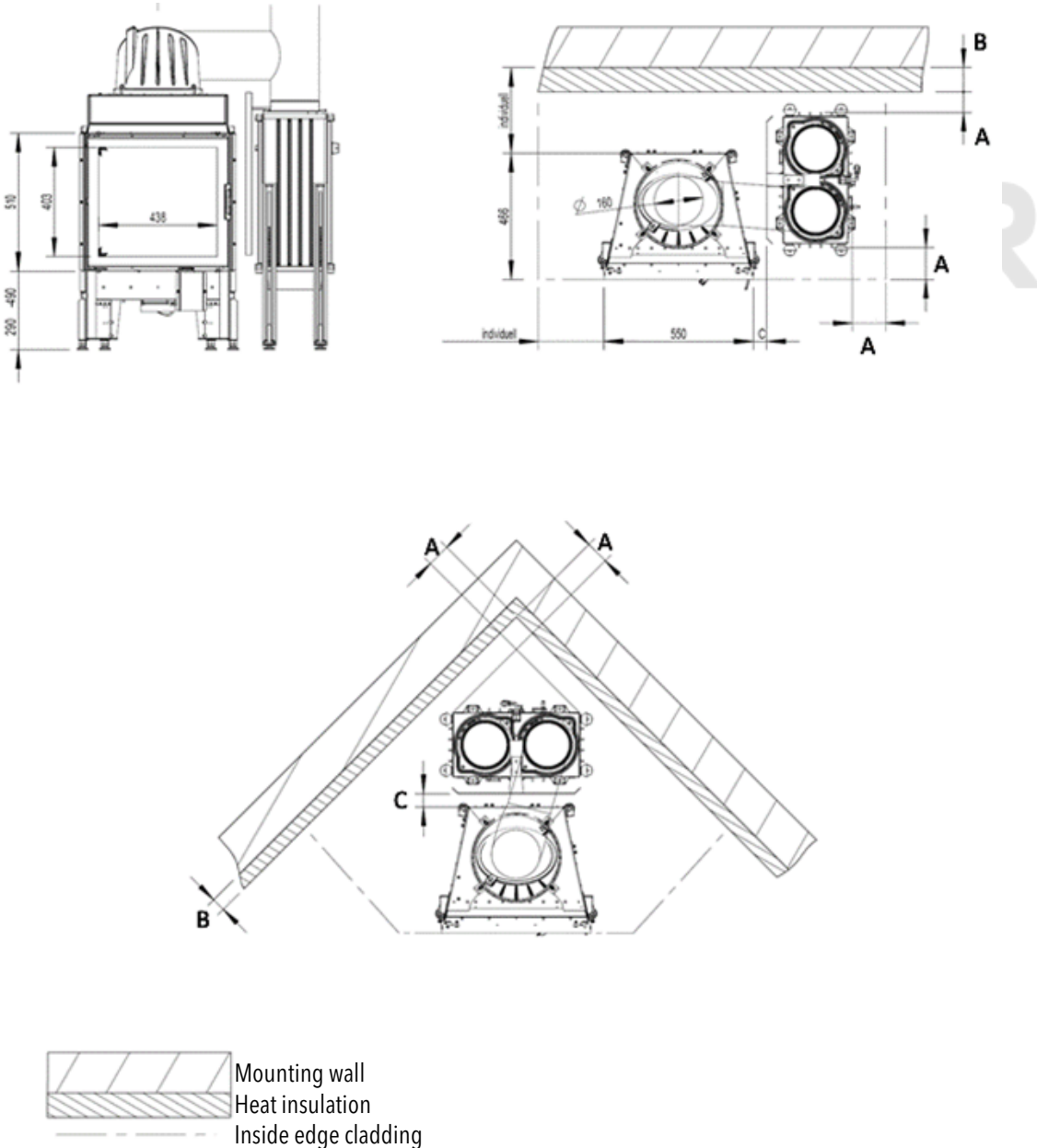

Dimension A: 75 mm

Dimension B: 90 mm (insulation materials pursuant to AGI Q 132)

Dimension C: 50 mm

Fig. 15: Connection to ceramic flue heat exchanger

11 Installation

Installation must only be carried out by an authorized specialist company.

Before installing the fireplace insert, check that all movable parts are working. Any defects before the installation of the fireplace insert must be reported.

11.1 Risks and dangers

Schutzausrüstung

The following protective equipment must be used:

Type of protective equipment	
	Safety gloves
	Safety shoes

Arbeitsmittel

The following work equipment is required for this step:

Work equipment	Activity
SW24 spanner	Various adjustment jobs
Slotted screwdriver	var. jobs on the sheet metal heat deflectors
pliers	var. bending jobs

11.2 Durchführung

11.2.1 Placing the fireplace insert

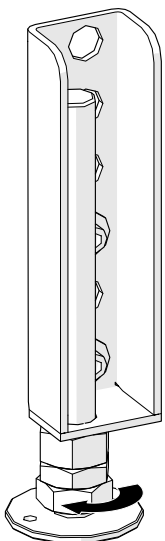

Fig. 16: Readjusting adjustable feet with SW24

- 1) Place appliance on prepared load-bearing base.
- 2) Adjust the four adjustable feet with an SW24 spanner.
 - Should the length of the threaded rod be insufficient, the four mountings can be adjusted in height.

11.2.2 Installing the deflector plates

The Keramott elements of the fire are already preinstalled. Only the Keramott deflections need to be installed.

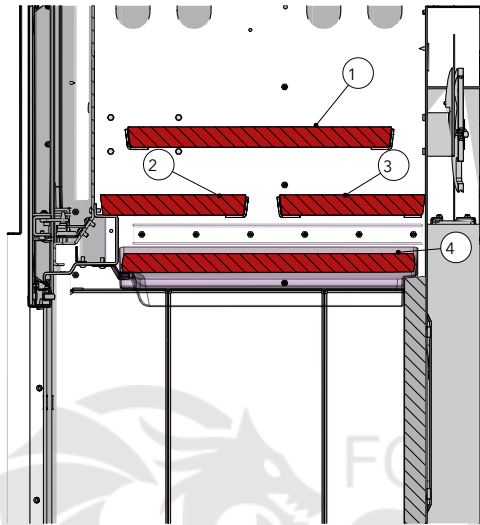

Fig. 17: 63x40x51 S left/right

63x40x51 S

- 1) First insert the upper baffle plate (1).
- 2) Then install the lower baffle plates (2-4) in sequence on to the brackets provided.

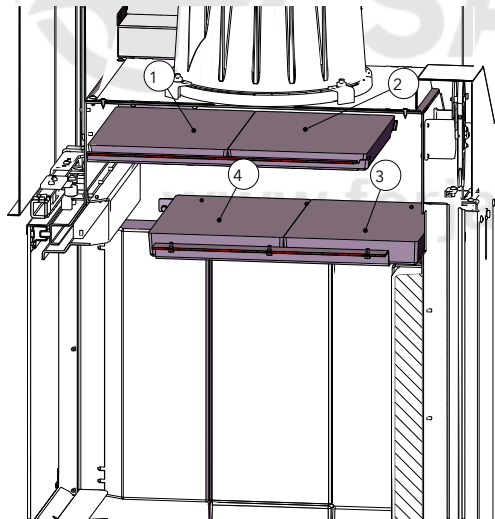

Fig. 18: Baffle plates 69x49x57 left

69x49x57 S (left+right)

- 3) First insert the upper baffle plates (1+2).
- 4) Then install the lower baffle plates (3-4) in sequence on to the brackets provided.

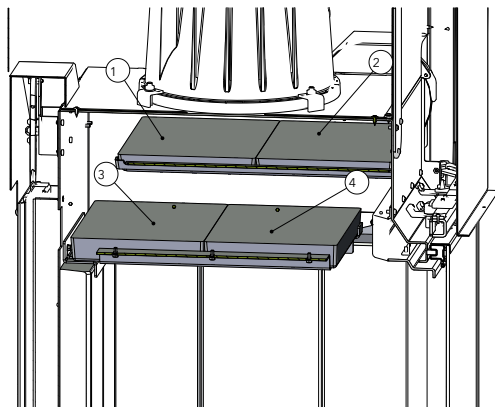

Fig. 19: Baffle plates 69x49x57 right

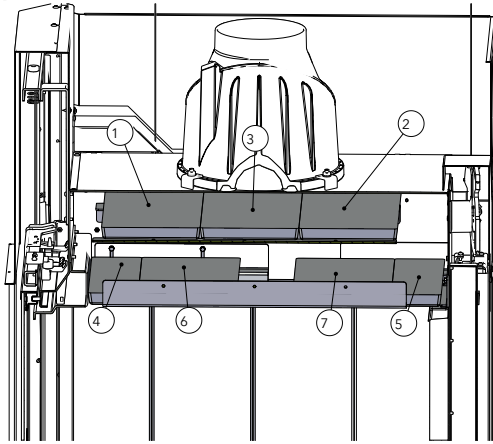

Fig. 20: Baffle plates 89x49s45 left

89x49x45 (left + right)

- 5) First insert the upper baffle plates (1-3).
- 6) Then install the lower baffle plates (4-7) in sequence on to the brackets provided.

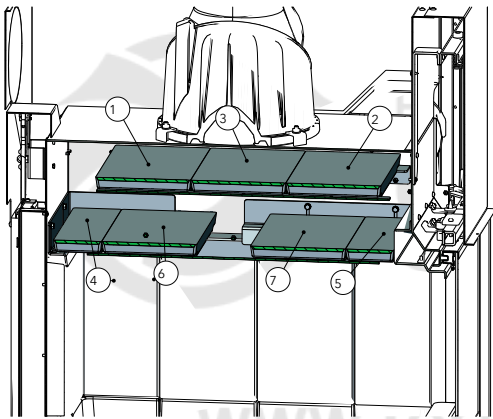
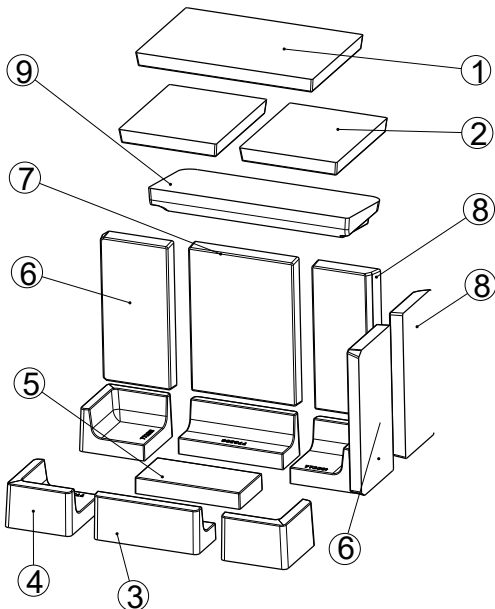

Fig. 21: Baffle plates 89x49s45 right

11.2.3 Installing the firebox lining (Keramott)



63x40x S

Numbering = installation sequence

Fig. 22: Keramott 63x40x42 S

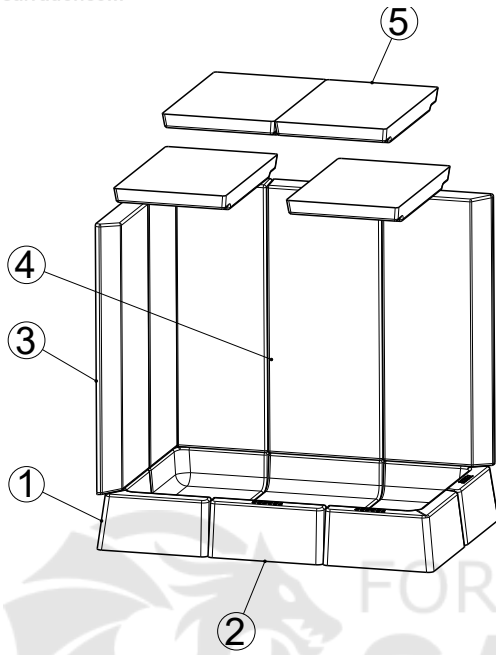

69x49x57

Numbering = installation sequence

Fig. 23: Keramott 69x49x57 KII

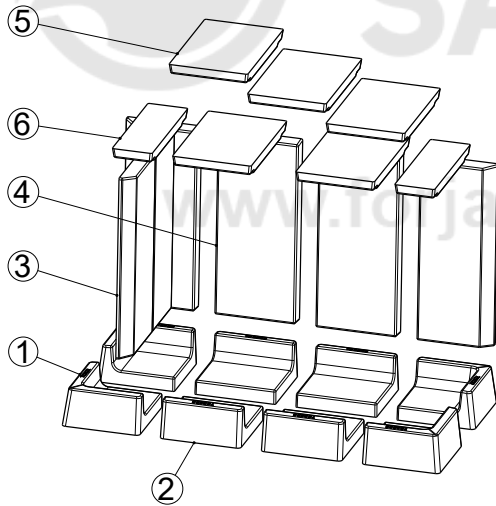

89x49x45

Numbering = installation sequence

Fig. 24: Keramott 89x49x45 KII



11.2.4 Removing the door

11.2.4.1 Eck sliding-door appliances

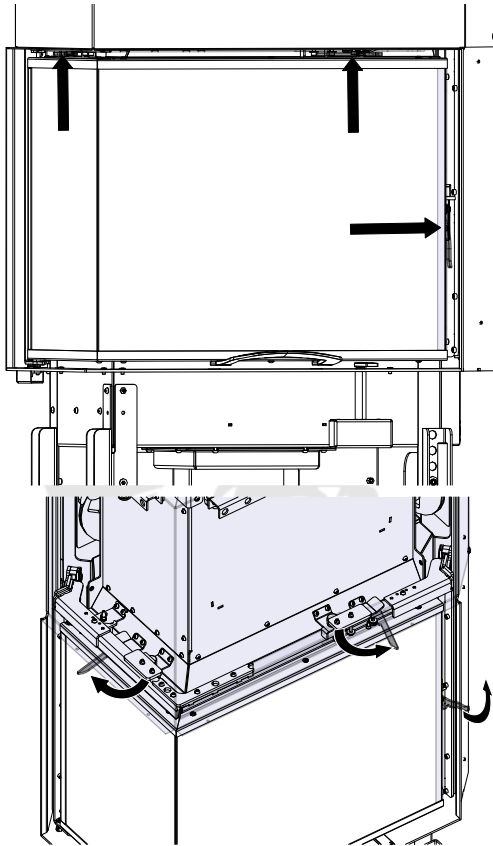

- 1) Open door lift.
- 2) Set the pivoting part to the rabbet and undo the door locks.

Fig. 25: Opening door lift

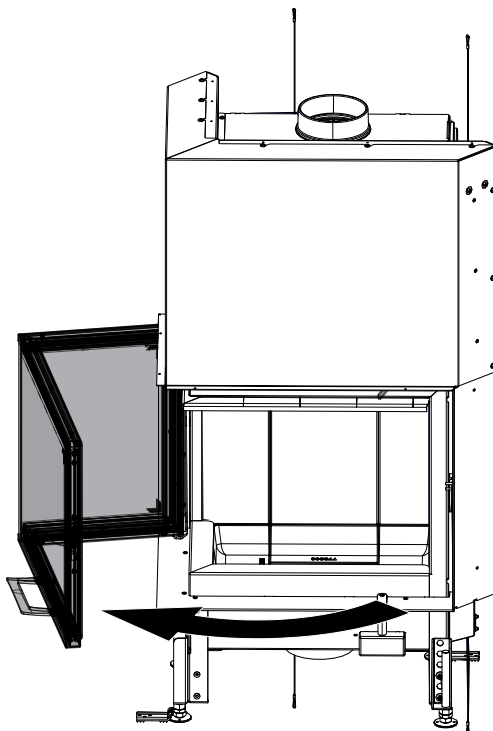

- 3) Open the door approx. 80° so that the trunnion pin of the pivoting part is in front of the door frame.

Fig. 26: Opening the door

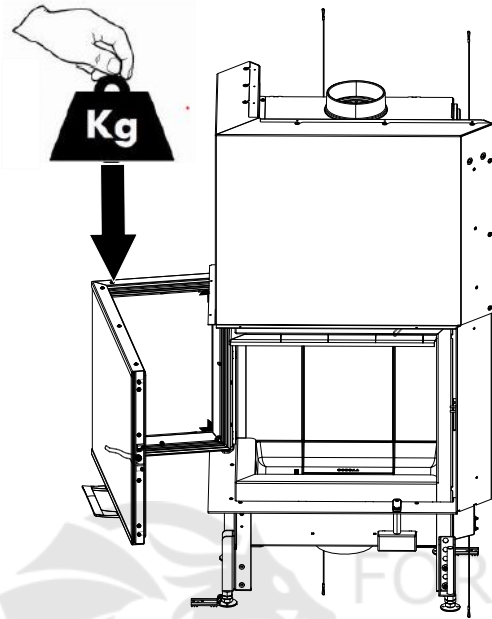

4) Do not prop the door.

Fig. 27: Do not prop the door

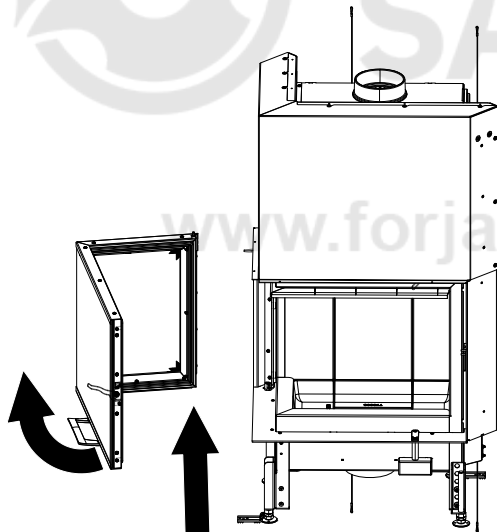

- 5) Lift the door and pivot it out of the lower hinge pin.
- 6) The door is installed in reverse order.

Fig. 28: Unhooking the door

11.2.5 Converting door to type BA2

Conversion from type BA1 (self-closing door) to type BA2 (non-self-closing door).

CAUTION

Risk of crushing injury

When removing the door, be careful not to trap your fingers/hand when the spring is released.

11.2.5.1 Eck sliding door appliances

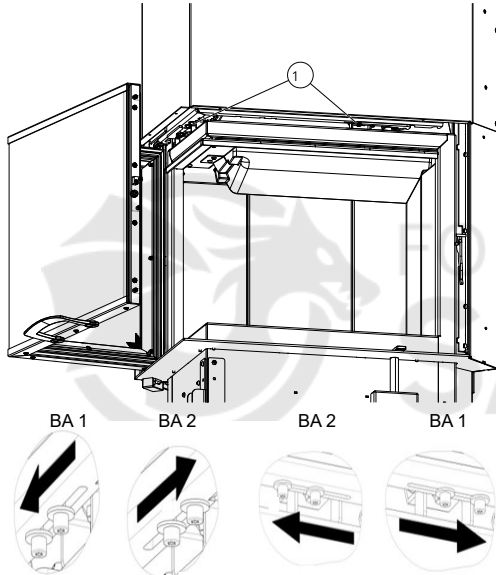

- 1) Lightly undo the marked screws and move the plates.
 - ⇒ If the plates are moved outwards, it is type 2 (BA 2). If the plates are inside, it is type 1 (BA 1)

Fig. 29: BA 1 to BA 2

11.2.6 Converting the flue pipe

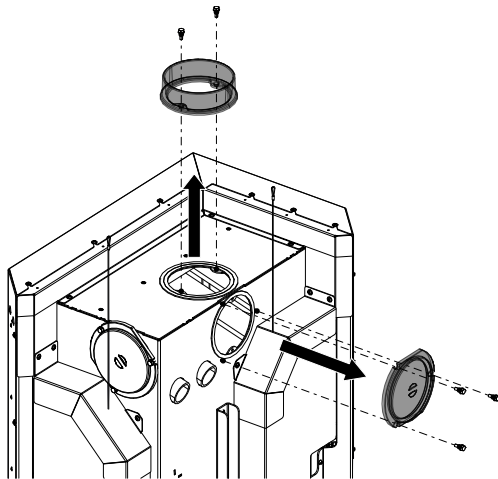

Fig. 30: Removing cover and flue pipe bracket

- 1) Detach cover on the rear or on the side.
- 2) Remove flue pipe bracket.

3) Change parts and reinstall.

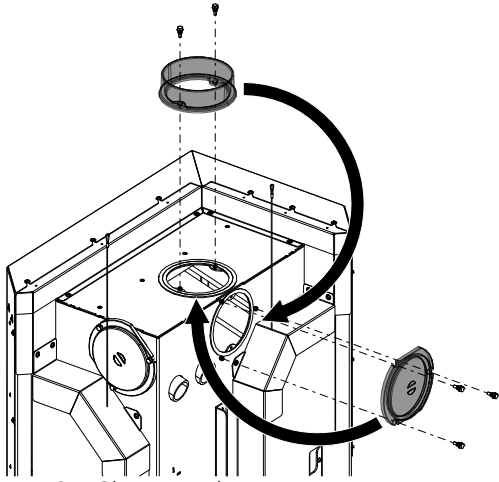

Fig. 31: Changing the parts

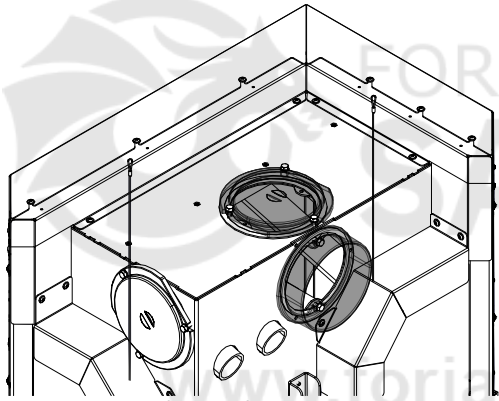

Fig. 32: Parts changed over

11.2.7 Installing the HMS

11.2.7.1 HMS 69x 89x

- 1) Detach radiation protection plate.

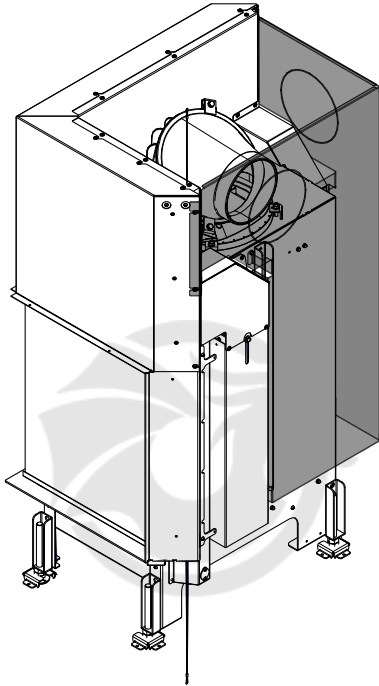

Fig. 33: Detaching the radiation protection plate

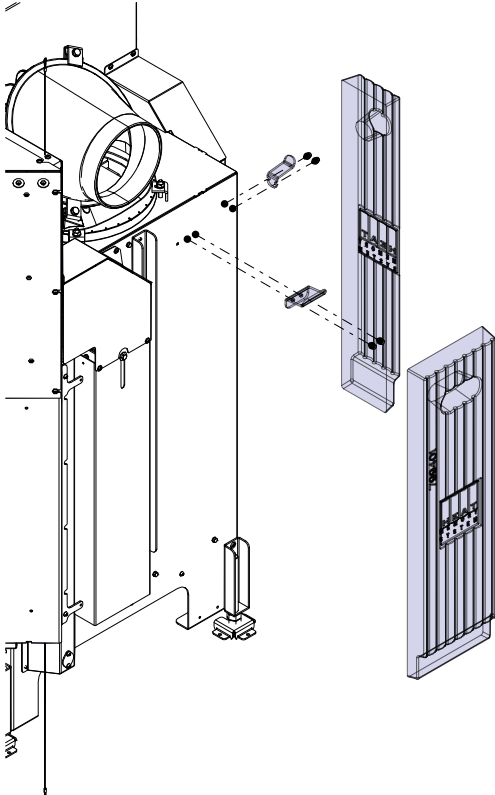

Fig. 34: Installing the HMS

- 2) Mount HMS mounting with the screws.
- 3) Attach HMS brick to the HMS mounting.
- 4) Repeat the previous two steps for the remaining HMS bricks.
- 5) Finally remount the radiation protection plate.

11.2.8 Mounting small top storage box

- 1) Remove flue pipe bracket.

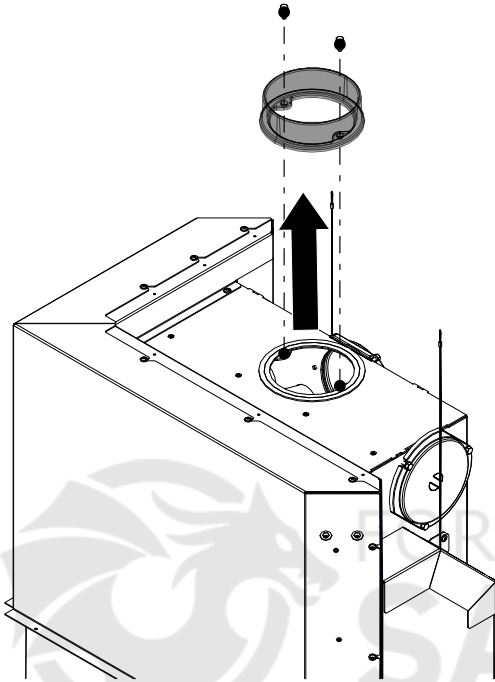

Fig. 35: Removing the flue pipe bracket

For models which have a smoke collector mounted, proceed as follows:

- 2) Detach the radiation protection plate.

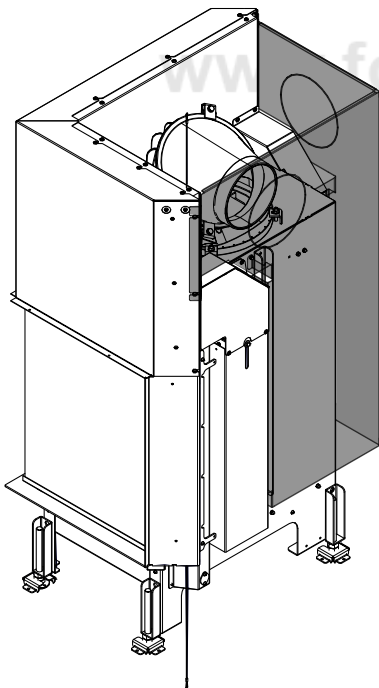

Fig. 36: Detaching the radiation protection plate

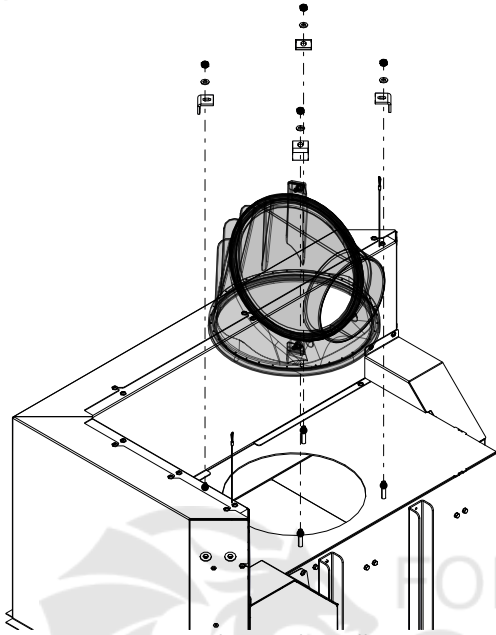

Fig. 37: Removing the smoke collector

- 3) Loosen hexagon nuts, washers and clamping shoe.
- 4) Remove smoke collector.

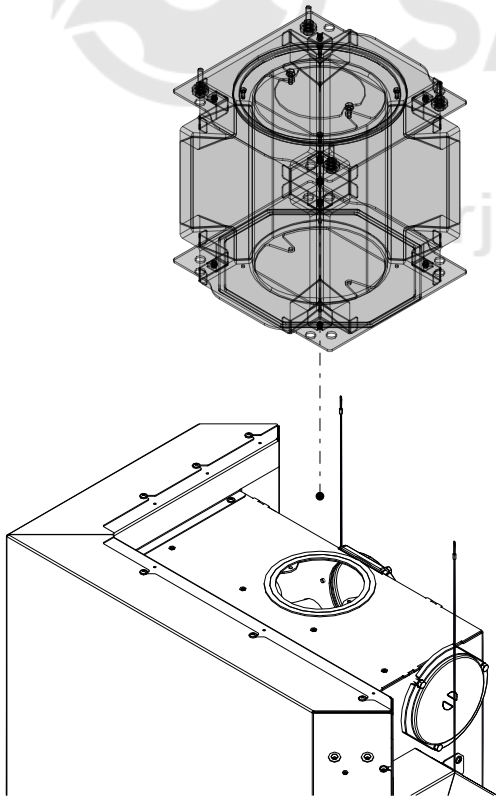

Fig. 38: Attaching the top storage box

- 5) Attach small top storage box to the fireplace insert.

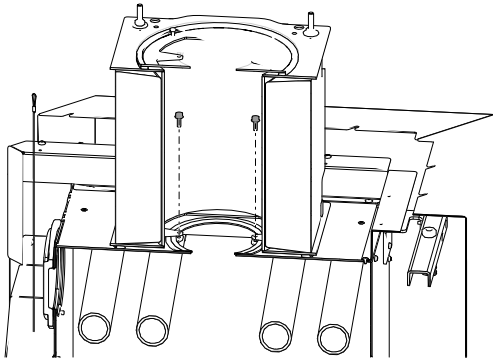
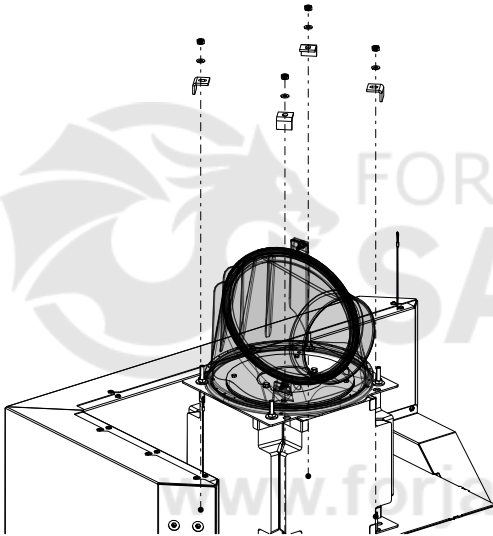

Fig. 39: Mounting top storage box

- 6) Use the screws to fix top storage box to the fireplace insert.



- 7) Place smoke collector (5) on to the small top storage box and fasten it to the bolt (4) with clamping shoe (3), washer (2) and hexagon nut (3) .
- 8) If necessary, bring the smoke collector into the correct position. To do so, see section Adjusting the smoke collector.

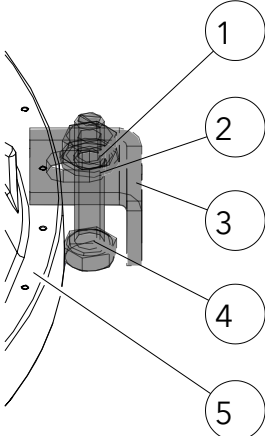

Fig. 40: Mounting smoke collector on top storage box

11.2.9 Assembling InsertControl

11.2.9.1 Installing InsertControl

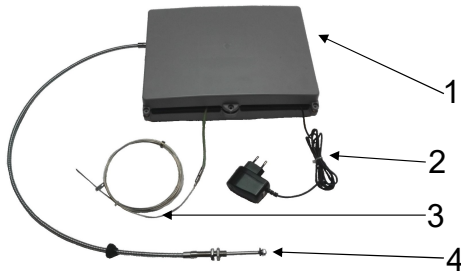

Fig. 41: Control unit

The control unit consists of:

- Control unit (1)
- Power unit (2)
- Temperature sensor (270 - 20 cm) (3)
- Bowden cable (100 cm) (4)

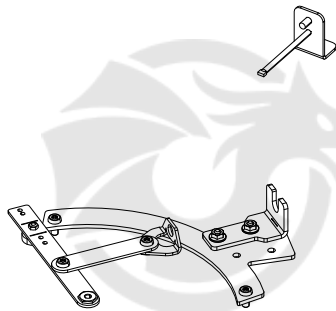

Fig. 42: Installation kit 363005

There are matching installation kits for the various fireplace inserts. The applicable fireplace inserts and the item numbers of the installation kits are:

- 63x40x42 S - 363005
- 63x40x51 S - 363005
- 69x49x57 S - 363006
- 89x49x S - 363007

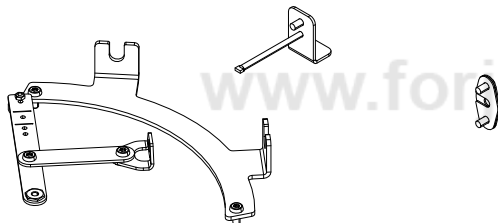

Fig. 43: Installation kit 363006

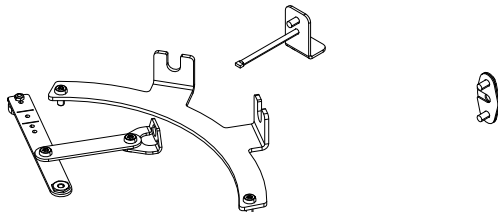

Fig. 44: Installation kit 363007

- 1) Set up the fireplace insert so that it is accessible all round for installation.
- 2) Remove the firebox lining (Keramott).

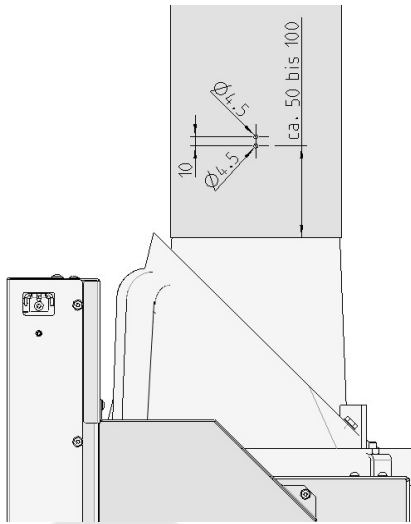

Fig. 45: Flue pipe drilling diagram

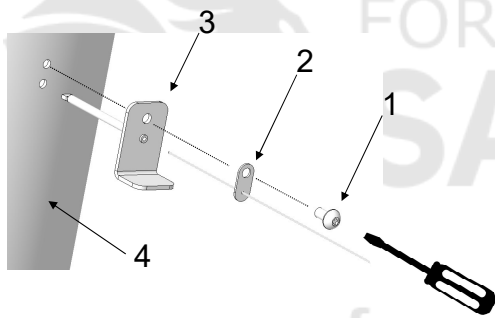

Fig. 46: Mounting the temperature sensor

3) Two holes must be drilled in the flue pipe for the temperature sensor. The position of the holes around the diameter of the flue pipe can be freely selected (see flue pipe drilling diagram).

4) To install the temperature sensor, you will require the following parts from the installation kit:

- ⇒ 1 x Taptite hex. LKS M5x10 (1)
- ⇒ 1 x thermocouple (2)
- ⇒ 1 x sensor conduit (3)
- ⇒ Torx screwdriver (not included in the installation kit)

5) Mount the temperature sensor on the flue pipe (4) as shown.

The holes for the Bowden cable have already been drilled beforehand for all fireplace inserts which have an InsertControl.

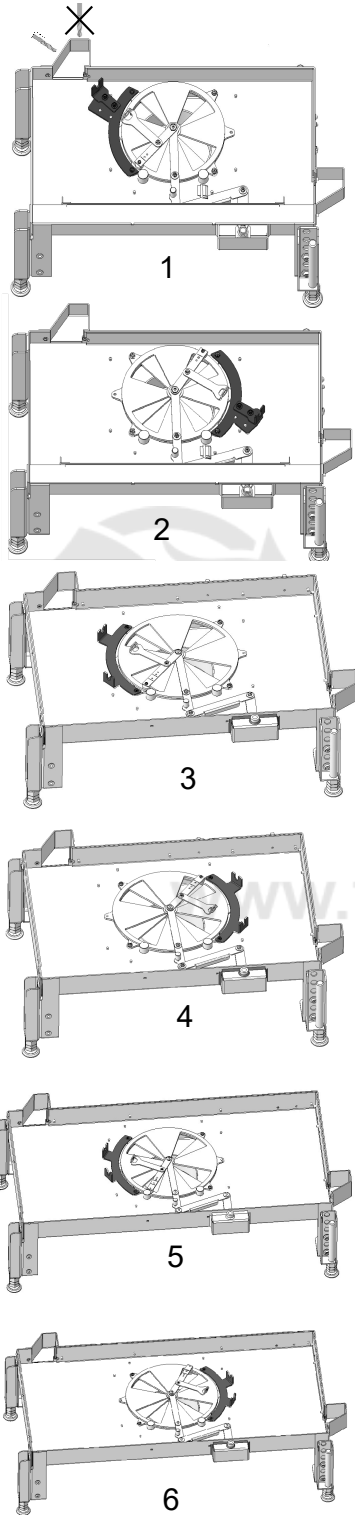

Here you can see the assembly situations:

- 63x (1) - installation on the left
- 63x (2) - installation on the right
- 69 x (3) - installation on the left
- 69x (4) - installation on the right
- 89 x (5) - installation on the left
- 89x (6) - installation on the right

Fig. 47: S Ecke installation left right

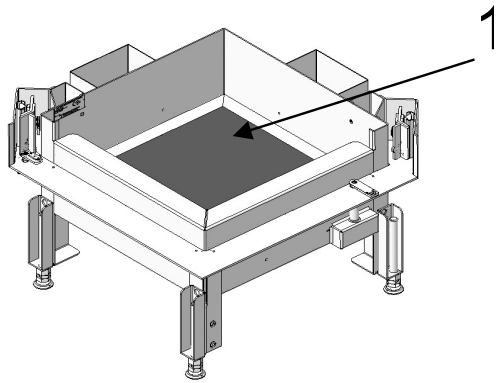

Fig. 48: Removing Keramott support plate

6) Remove Keramott support plate (1).

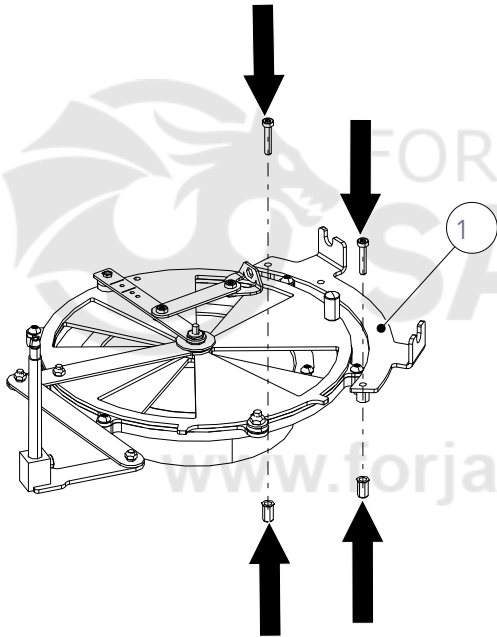

Fig. 49: Installing the installation kit

In the following illustration the 363000 installation kit has been installed in the left-hand version.

Depending on the appliance, installation kit and left- or right-hand assembly situation, for installing the mounting, other screws will have to be removed and installed again. You can find this in the illustrations showing the assembly situations of your stove/installation kit and in the detailed drawing in the installation kit.

7) Install the installation kit (1) as shown.

⇒ After installing the installation kit, check the free movement of the air regulator.

8) To do so, move the air regulator several times from the minimum position to the maximum position. Should there be no free movement of the air regulator, check the following:

⇒ Has the installation kit been correctly installed.

⇒ Are the screw joints on the air regulator disc excessively tightened?

If the air regulator can be easily adjusted, the assembly of the connection between installation kit and control unit can be continued.

9) Remove the two M10x1 (1) and the M5 nut with flange (2) and the spacer connecting plate (3).

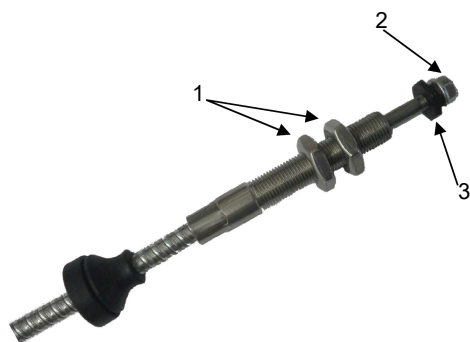

Fig. 50: Installing the control unit

For the connection between control unit and installation kit you will require the following part from the installation kit:

- 2 x Taptite hex. LKS M5x10
- 2 x flange Bowden cable
- Torx screwdriver (not included in the scope of delivery)

The installation point of the control unit must be chosen so that the following items are guaranteed:

- The ambient temperature of the control unit must not exceed 50°C.
- The control unit must be accessible.
- A maximum of 2 curves must be laid with the Bowden cable.
- The curve radius of the Bowden cable must not be smaller than 100 mm.

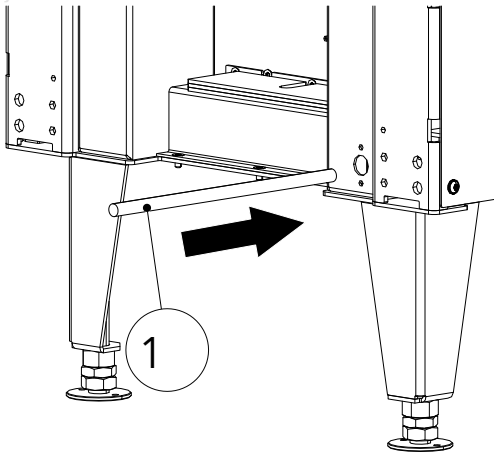

Fig. 51: Threading the Bowden cable

- 10) Thread the Bowden cable (1) through the Ø16 hole in the fireplace insert.

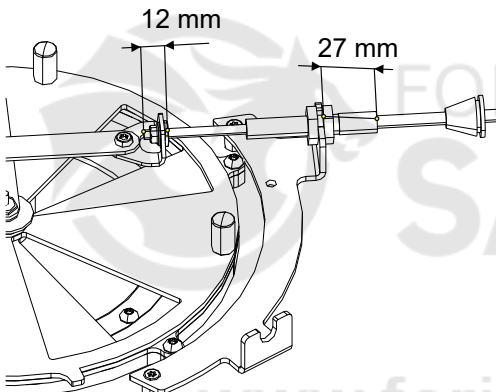

Fig. 52: Connecting the Bowden cable

- 11) Connect the Bowden cable to the installation kit.
 - ⇒ Pay attention to the installation dimensions. The 27 mm and 12 mm dimensions are the same for all the installation kits.

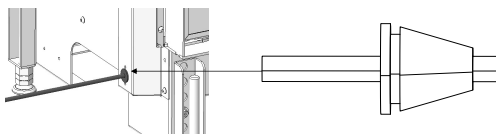

Fig. 53: Engaging the rubber plug

- 12) Slide the rubber plug far enough into the fireplace insert that the groove in the rubber plug engages.

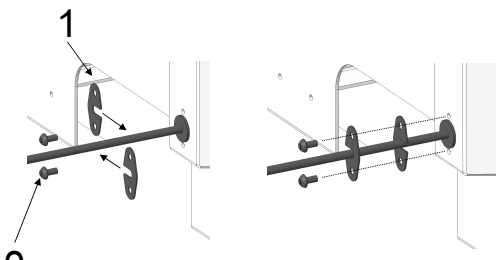

Fig. 54: Bowden cable flange

- 13) Slide the Bowden cable flange (1) over the Bowden cable once each from left and right.
- 14) Then use the Taptite screws (2) to screw the two flanges (1) on to the fireplace insert.
- 15) After screwing in, check whether the rubber plug is firmly seated and correctly positioned all round. After the fireplace insert has been installed, this area will no longer be accessible!

11.2.9.2 InsertControl function test

TIP

Before the fireplace insert is reassembled, a function test should be carried out.

- Make sure that all components are correctly assembled with one another
- Plug the power supply into the socket
- The controller now moves to the maximum positions of the motor (calibration run)
- Wait about 10 minutes after plugging in the power supply and check in that time that the air regulator disc has completely closed and opened
- After the 10 minutes has finished the air regulator disc must be either completely opened or closed (depending on the program set)

TIP

After a successful function test the fireplace insert can be completely reassembled.

Should the air regulator not have completely opened and closed after the 10 minutes has finished, check the following:

- Check whether the installation kit has been installed according to the drawing
- Check whether the screw connections on the air regulator disc might have been excessively tightened
- Check if the Bowden cable is possibly caught or blocked by a foreign body
- Undo the connection between Bowden cable and installation kit
- Check whether the installation kit can be easily adjusted without the Bowden cable
- Check the Bowden cable for contamination. If it is contaminated, clean the Bowden cable. **DO NOT LUBRICATE!**
- Run the function test once more without the control unit being connected to the installation kit. When doing so check whether the shaft of the Bowden cable reaches a distance of 38 mm.

11.2.9.3 How the InsertControl automatic combustion control works

InsertControl reacts only to differences in the flue gas temperature that take place within certain periods. This information is transmitted by the temperature sensor to the controls. Should the temperature sensor be defective or display a fault, the controls will automatically go into fault mode with 60% shutter opening and no longer changes this position.

Operation

The InsertControl software consists of the following 6 program phases.

- Calibration
- Standby
- Ignition phase
- Combustion phase (air regulator 60 % (Eco) or 80 % (Normal))
- Stoking phase
- Ember phase

Calibration: The calibration (see above) of the controls is carried out when the controls are connected to the mains or the WLAN is changed, but only if the flue gas temperature is below 80 ° C. In the process the control software detects where the positions 0% and 100% shutter opening are on its fireplace insert. After the controls have detected the two maximum positions, they run to the 0% shutter opening (if the correct program has been chosen) and switches into the Standby phase.

This process requires approximately 10 minutes. Should the flue gas temperature be above 80°C, no calibration run is carried out. The controls use the data from the last calibration run that was carried out.

The programming of the controls includes various "Eco" and "Normal" combustion curves. Each of these two modes is available with the "sliding opening" and "sliding closing" function.

Program overview		
Selection wheel	Mode	Function
Position 0	-	Shutter opening, always 60%
Position 1	Normal	sliding opening
Position 2	Eco	sliding opening
Position 3	Normal	sliding closing
Position 4	Eco	sliding closing

Selecting the program

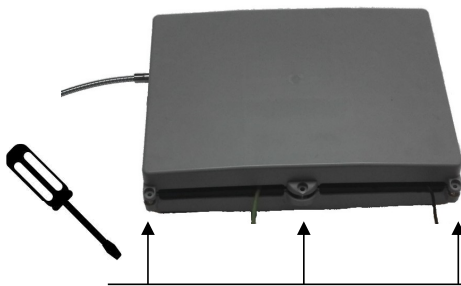

Fig. 55: Unplugging the power supply

- 1) Remove power supply from the socket.
- 2) Remove the three screws and open the control unit housing.

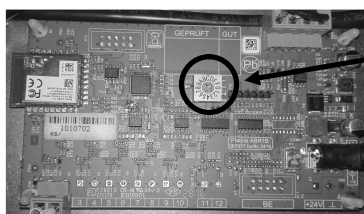

Fig. 56: Selecting the program

On the circuit board is a selector switch (1) that by default is set to position "0".

- 3) Select program by setting the arrow of the selector switch to position 1, 2, 3 or 4 (see "Program Overview" table).
- 4) Before closing the controls again, carry out a fresh calibration by plugging the power supply back in.
 - ⇒ If you have selected the correct "sliding closing" or "sliding opening" function, after the calibration the controls must complete close the shutter.
 - ⇒ Should you notice that you have chosen the wrong program, you can change this in the service menu of the app.

APP

The InsertControl function can be monitored using the app on iOS and Android Smartphones. To do so, first load the "InsertControl" app from the iTunes Store or Google Play on to your Smartphone.

When it is connected to the circuit, InsertControl creates a WLAN with the name "ABR_xxxxxxx" (xxxxxxx = serial number of the controls). You must connect your Smartphone to this network (password: 12345678). After the app is started, the connection is automatically established.

If desired you can then connect the app to another WLAN (in the app's settings menu). Please note that a new calibration run for the controls will then be started.

11.2.10 Mounting the convection cladding

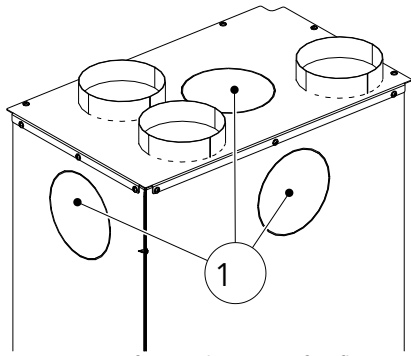

Fig. 57: perforated cut-out for flue pipe

Before the KV cladding is installed, the perforated cut-out (1) must first be removed using a saw. At which point the plate is removed depends on where the flue pipe connection is located.

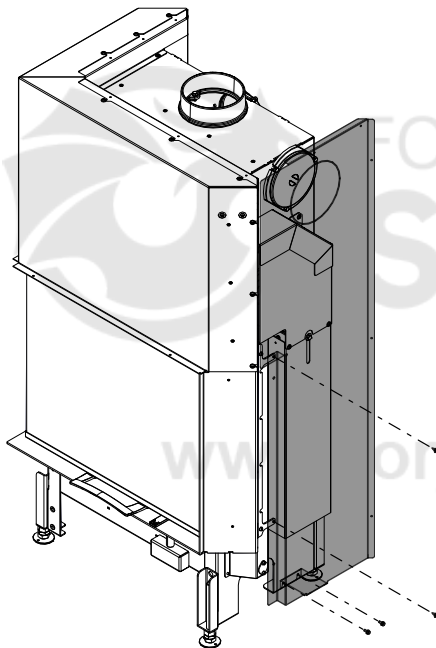

Fig. 58: Attaching and fastening KV cladding side

- 1) Attach KV cladding side to the fireplace insert and fasten with screws.

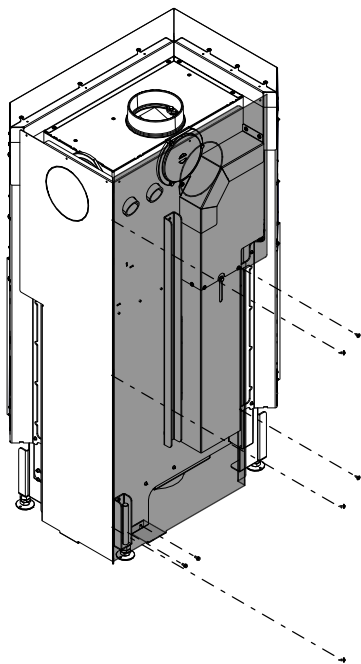

Fig. 59: Attaching and fastening KV cladding at rear

- 2) Attach KV cladding side to the fireplace insert and fasten with screws.

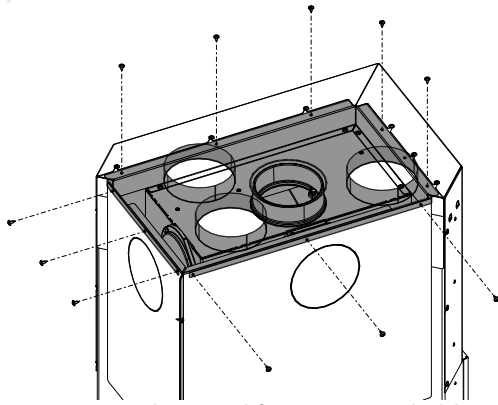

Fig. 60: Attaching and fastening KV cladding cover

- 3) Attach KV cladding cover to the fireplace insert and fasten with screws.

11.2.11 Mounting the design frame

NOTICE

Design frames must not be plastered over nor walled in.

11.2.11.1 Design frame

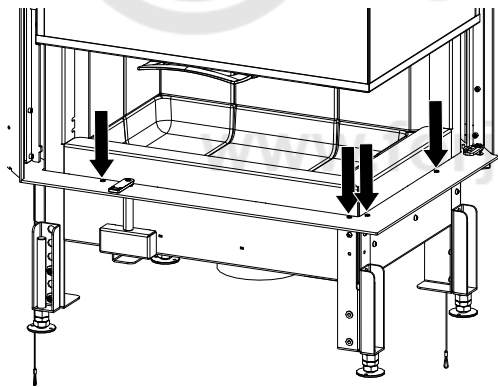

Fig. 61: Opening the door slightly and undoing the screws

- 1) Open the door slightly and undo the marked screws.

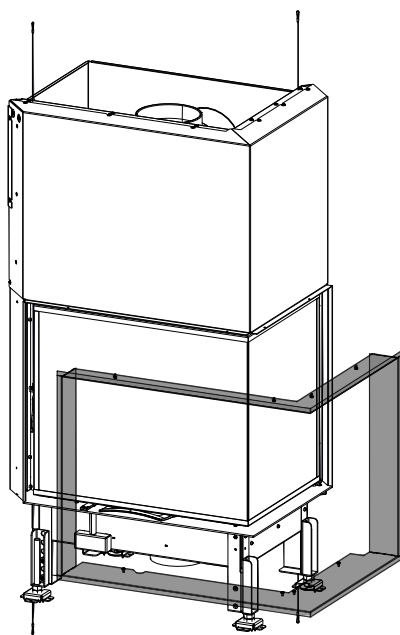
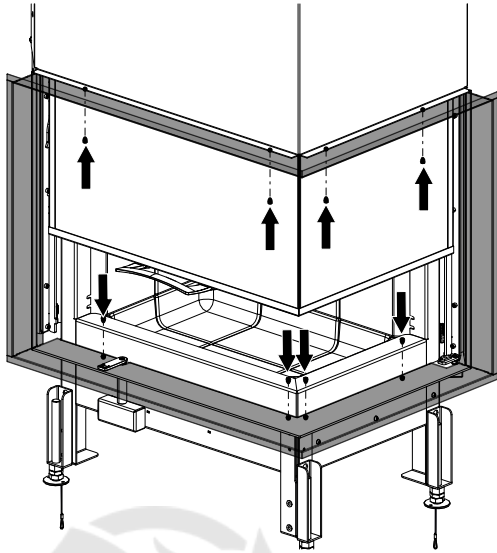

Fig. 62: Attaching the design frame

- 2) Attach design frame to the fireplace insert.



3) Fasten design frame with the screws.

Fig. 63: Fastening the design frame

11.2.12 Solidly mounting the design frame

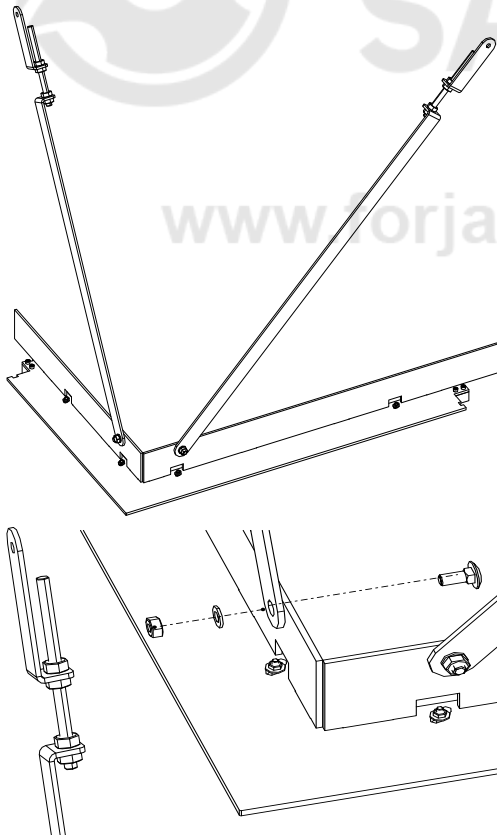

1) Mount parts as per the drawing.

Fig. 64: Mounting the parts

www.forjas-salvador.com

www.forjas-salvador.com

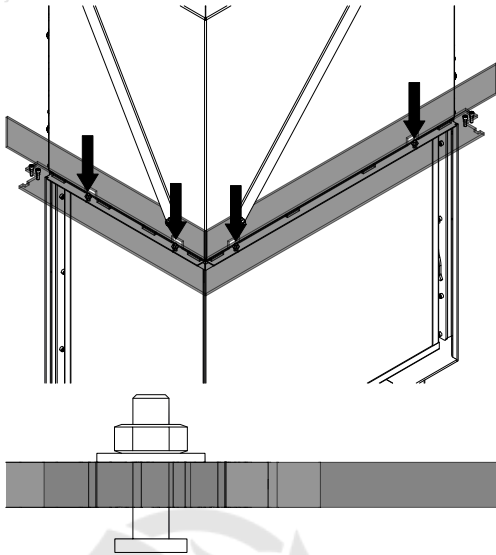

Fig. 65: Mounting the design frame at the top

- 2) Mount designer frame at the top. Only loosely tighten the screws and nuts.

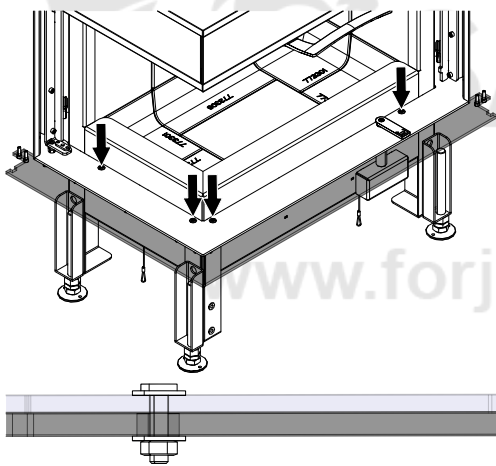
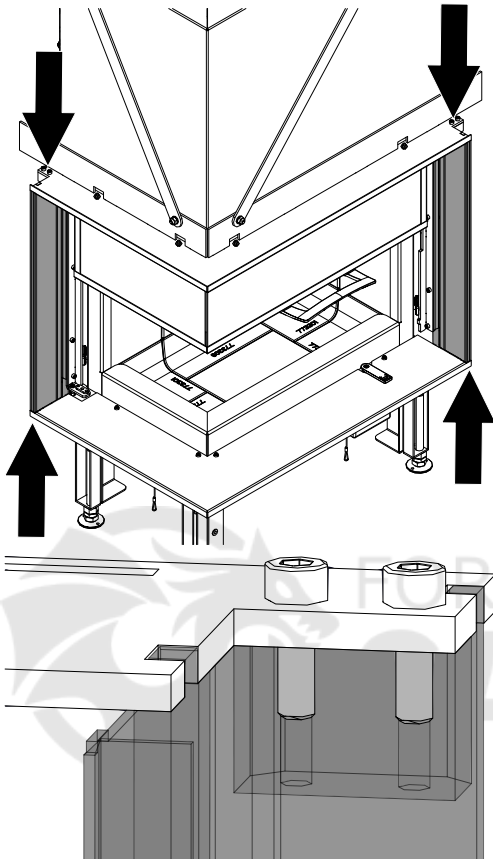

Fig. 66: Mounting the designer frame at the bottom

- 3) Mount the designer frame at the bottom. Only loosely tighten the screws and nuts.



- 4) Position design frame and use M5x16 hexagon socket screws to screw up at the top and bottom.
- 5) Repeat this step for on the right-hand side of the fireplace insert.

Fig. 67: Mounting the design frame on the left and right

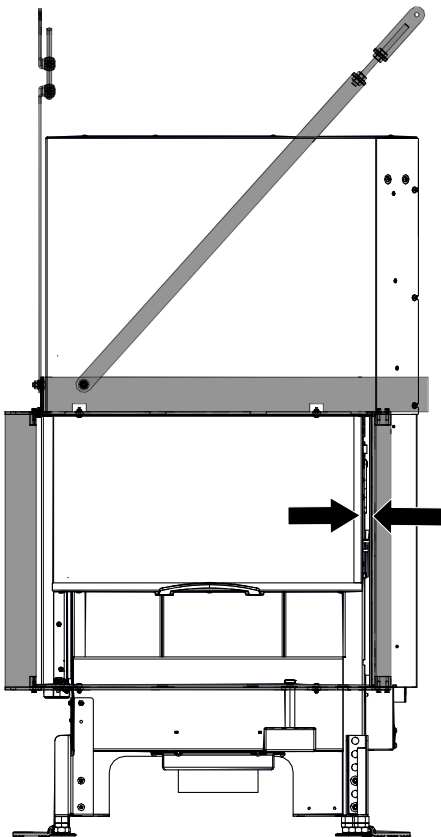

- 6) Evenly align the frame and first tighten the bottom screws, then the top ones.

Fig. 68: Evenly aligning the design frame (right-hand model)

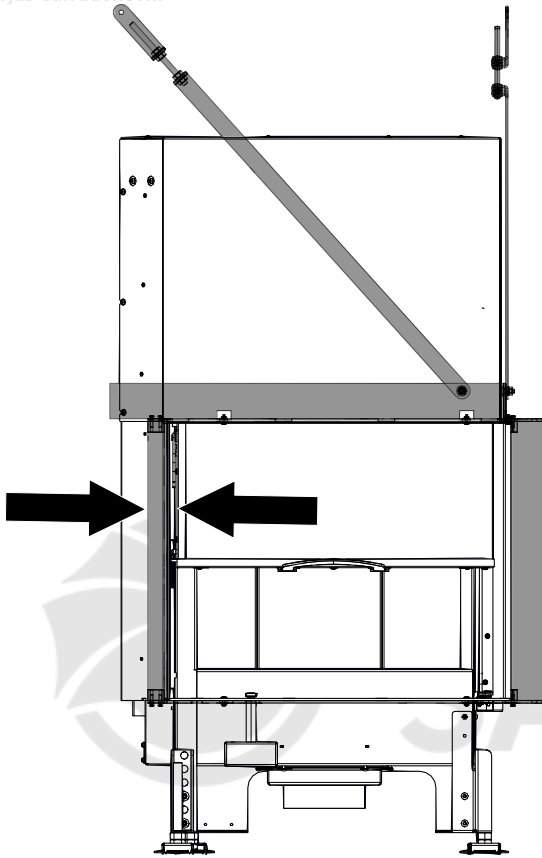

Fig. 69: Evenly aligning the design frame (left-hand model)

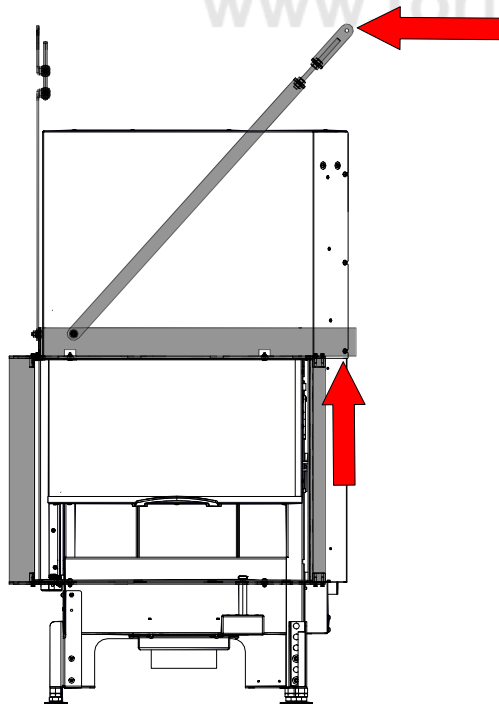

Fig. 70: Loading the design frame (right-hand model)

7) Evenly align frame and tighten all the screws.

NOTICE

The frame can only be loaded if the weight that is resting on the frame is supported via the tensioning parts and the lower part of the solid designer frame.

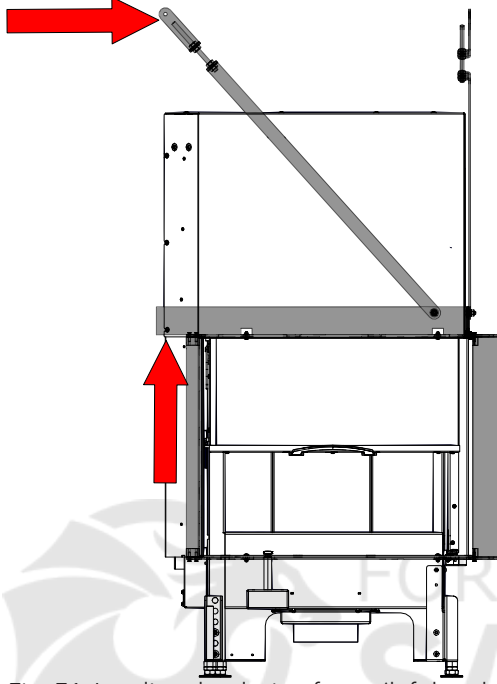
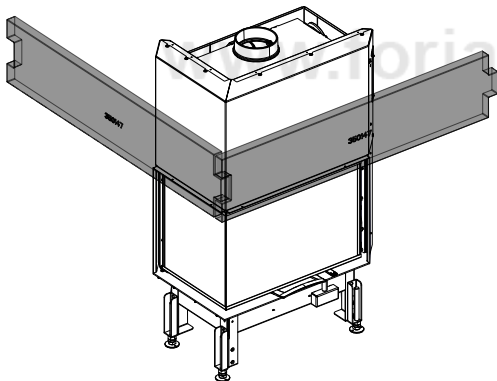

Fig. 71: Loading the design frame (left-hand model)

11.2.13 Support frame



Support frame made of cast chamotte

Fig. 72: Cast chamotte support frame

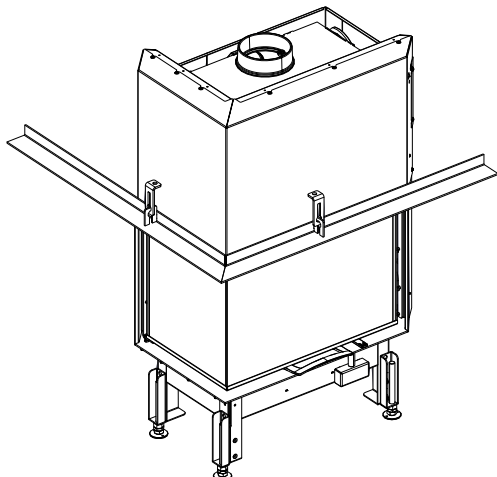

Support frame

Fig. 73: Support frame

12 Settings

12.1 Adjusting the tuning weight

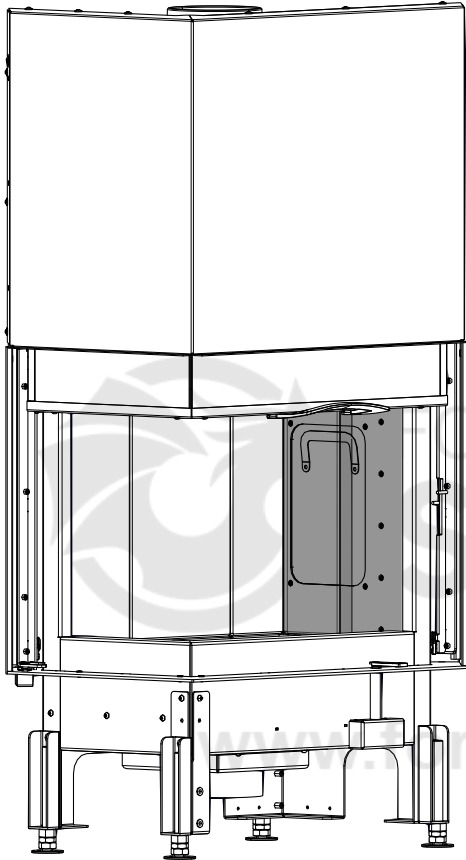

Fig. 74: Removing marked Keramott bricks

Adjustment of the tuning weight is required so that the sliding door does not close too quickly.

If the sliding door closes too quickly, more tuning weight is required.

You will have received two additional tuning weights with your fireplace insert. These can be used to adjust the closing force of the door as necessary.

- 1) Remove side Keramott bricks (either left or right, depending on the model).

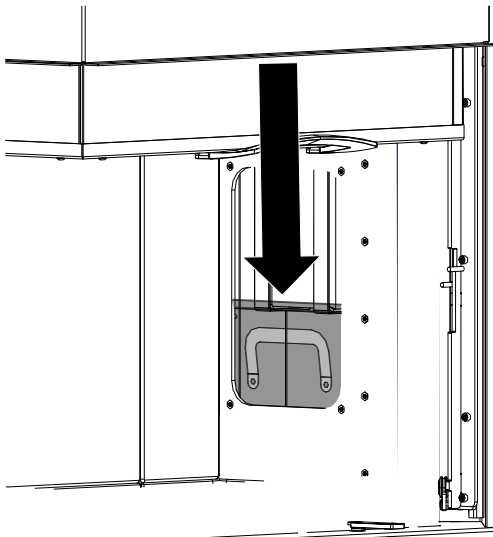
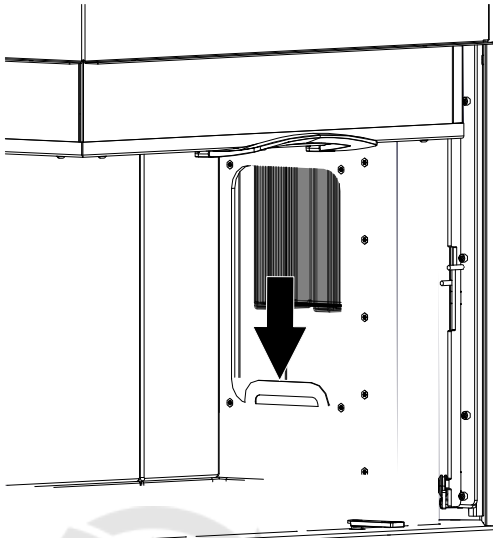

Fig. 75: Pushing the cover down

- 2) Push cover down.



3) Pull out main weight and detach it from the rope.

Fig. 76: Pulling out the main weight

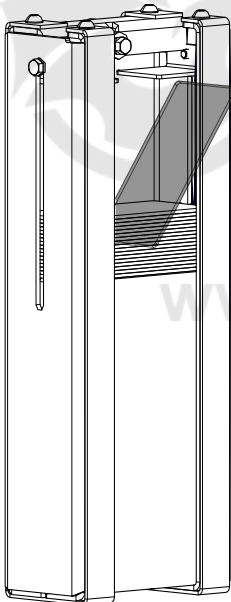

4) Position weight slightly diagonally and insert it.

Fig. 77: Inserting the weight

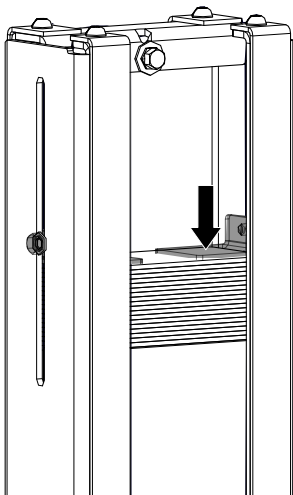

5) Lightly tighten the screws on the sides and place the brackets on the weights, and tighten the screws again.
⇒ These brackets are used to stop the weights from moving when the door is opened and closed.

6) Reattach the main weight in reverse order.

Fig. 78: Setting up the brackets

13 Commissioning

13.1 Initial Commissioning

- ✓ The initial commissioning of your fireplace should take place 4 weeks at the earliest after completion of the cladding, so that all cladding parts are able to dry out completely.
- 1) Remove all enclosed documents and appliance parts from the fireplace.
- 2) Read the operating manual through carefully before the initial commissioning.
 - ⇒ For optimally lighting we refer you to the section Firing [► auf Seite 82] explained.
 - ⇒ During the first fire after the system has been completed, this should be kept very small in the first hour and only gradually increased by increasing the amount of wood laid. However the amount of wood laid per hour must not be exceeded in the process.
 - ⇒ The odours during the first fire are caused by the evaporation of sheet metal greases and binding agents from the varnishing. Although unpleasant, these fumes are completely non-toxic. We therefore recommend that you well ventilate the room for the first few fires.

NOTICE

To avoid damage you must **NEVER** operate your Stove a greater quantity of fuel than that specified in this manual!

www.forjas-salvador.com

14 Operation

14.1 Controls

The appliance series are characterised by being extremely simple to use.

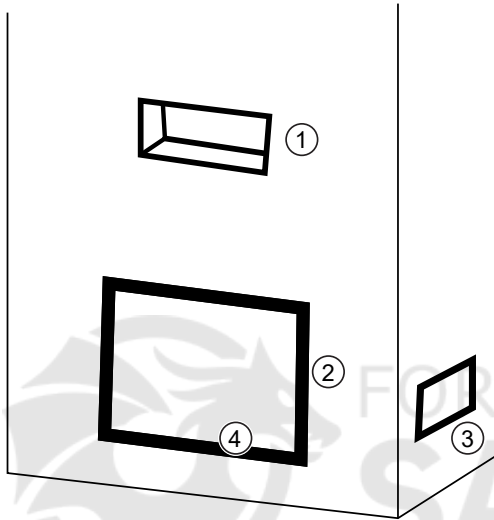

Fig. 79: Operating functions on the appliance

Operation

1	Convection outlet
2	Door lock
3	Convection inlet
4	Combustion air controller

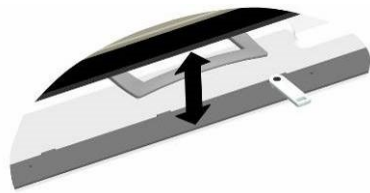

Fig. 80: Door lock - sliding door

Door lock

Opening the door:

- Raise lock

Close the door:

- Lower lock

Combustion air controller

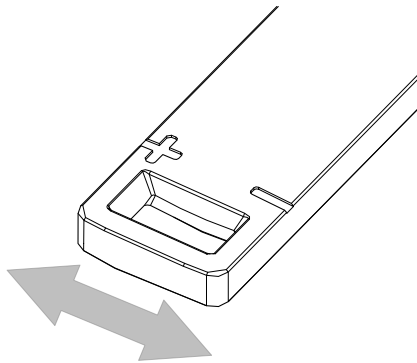

+	Maximum air feed for fast burning
-	Low heat output
I	Average heat output

14.2 Before heating up

The stove can only function properly if there is sufficient combustion air coming to the room of installation (the appliance), specially if several firing installations are being operated at the same time. Ensure sufficient air supply before heating up. Open the combustion air flap on the appliance and keep it open for the entire combustion period.

Devices for the supply of combustion air must not be modified.

14.3 Fuel

NOTICE

To avoid damage you must **NEVER** operate your Stove a greater quantity of fuel than that specified in this manual!

Approved fuel

Dry, properly stored, unrefined log (preferably hard wood) is permitted as fuel for our hybrid stoves. Round wood must be split at least once so that it lights better. The diameter of the split piece of wood must not exceed 7 cm.

Maximum fuel quantity

Every fireplace insert is designed for a maximum fuel quantity: see Technical Data section.

Clean combustion

To achieve clean, low-emission combustion, dry (relative wood moisture < 20 %) and untreated firewood must be used. (In addition to a lower calorific value, wet wood causes the panes of your fireplace insert to become tarnished with soot more quickly). Secondly, the correct amount of firewood must be burnt. Heat responsibly with dry firewood to protect both people and the environment.

Fuel

Only burn the recommended fuel.

Explosive substances

It is strictly forbidden to burn or introduce highly flammable or explosive substances (empty aerosols and the like) into the firebox or to store them in the immediate vicinity of your stove. Risk of explosion!

14.4 Firing

To ensure the heating appliance operates correctly and safely, it is important that the chimney generates the required draught. This must be checked in particular for each initial commissioning (e.g. after summertime) and in the transitional periods (e.g. strong wind, fog, etc.). For this purpose, hold a lighted match or cigarette lighter flame to the opened fire door. If the flame is not drawn into the opening, lift must be created in the chimney by a strong generation of heat (e.g. by paper or kindling). If this does not succeed, then the stove must not be started up!

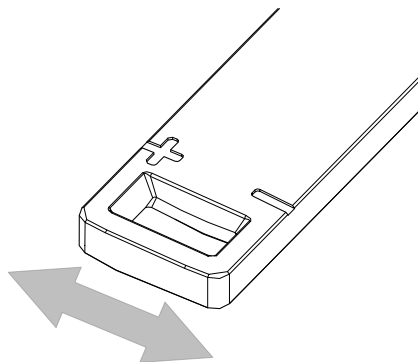

- 1) Turning the combustion air controller regulator completely to the left to the "+" position

- 2) If there is a throttle valve, open it fully.

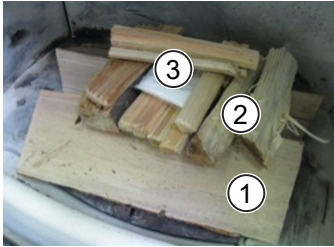

Fig. 81: Before kindling

- 3) Lay 2-3 pieces of log (1) (beech, oak, birch) across the bottom of the firebox.
- 4) Finely split softwood above it (2).
- 5) Place a firelighter (3) in the middle and light it.
⇒ Never use petrol, spirit or similar for ignition!

1	Log
2	Softwood
3	Firelighter



- 6) As soon as the logs have burned well all around after a few minutes, close the combustion air controller by approx. 50% (bring the regulator to the middle position) or close the throttle valve, if available, by 50% (handle to the left).

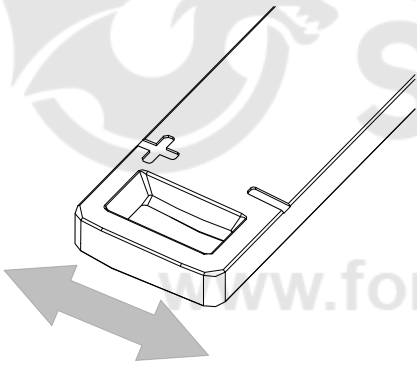

14.5 Heating

- 1) Combustion air damper maximum 50 % opened (regulator to middle position). Otherwise the amount of fuel laid burns off too quickly and the temperatures on the appliance become too high.
- 2) Throttle valve, if present, 50 % opened. Otherwise the amount of fuel laid burns off quickly.
- 3) Completely open all available warm air grilles.
- 4) If there are only embers left in the firebox, stoke up.

14.6 Putting on wood

Please note that the fireplace inserts are not slow-burn fires. These are temporary-burning fires, i.e. longer continual operation is achieved through repeated stoking up.

No loose or easily flammable items of clothing should be worn when laying the fire.

The right time for stoking up has come when the fuel has burnt down to the ember phase. Further deposits of wood are then generally no longer necessary.

Putting more wood on:

- 1) Fully open air control lever.
⇒ This prevents any eddies that would allow flue gases to escape. If there is one, fully open the throttle valve.
- 2) Fully open throttle valve.
- 3) Slowly open door.
- 4) Put wood on.
- 5) Close doors.
- 6) When the wood is burning properly, close the air control lever back to about ½ position and close throttle valve again up to 2/3 (turn to the left).

14.7 Heating in the transition period

In the transition period, i.e. during high external temperatures, a sudden temperature rise can disrupt the chimney draft so that the fuel gases are not completely drawn off. In this case the appliance must be filled with smaller quantities of fuel and operated with the air damper/-controller on a higher setting so that the available fuel combusts more quickly (with a flame developing) and the chimney draft stabilized as a result.

TIP

To prevent resistance in the firebed, the ashes should be removed more frequently.

14.8 Heating with the ceramic flue (heat recovery surface)

If your system is fitted with a ceramic flue (or with a metal heat recovery surface), the the following must be observed during heating operation:

- During heating operation via the heat recovery surface, the firebox door must not be opened (escape of exhaust gas). When putting more wood on, the deflection flap must first be opened. Only then can the firebox door be opened.
- The deflection of the fuel gases via the heat recovery surface can take place 15 minutes at the earliest after firing. Otherwise there is the danger of an uncontrolled escape of exhaust gas above the door frame.
 - Turn to the left -> opens flap`
fuel gases are routed directly into the chimney. In this position the firebox door can be opened.
 - Turn to the right -> closes flap
fuel gases are routed directly via the heat recovery surface. This can only take place with the firebox door closed.

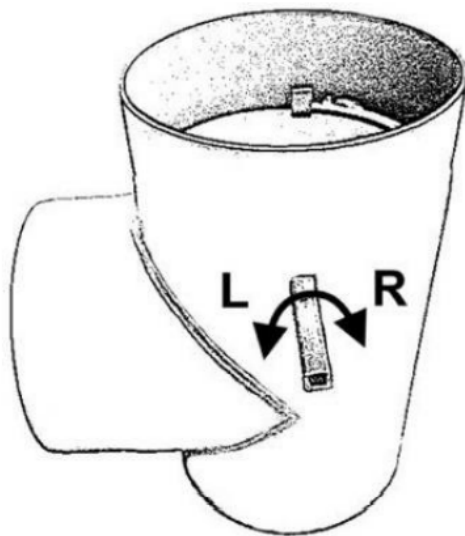



14.9 Operation

We would particularly like to point out at this point that Austroflamm fireplace inserts must only be operated with doors closed. The best efficiency and thus optimal fuel efficiency is achieved in closed operation.

DANGER

Fire hazard

Open operation of Austroflamm fireplace inserts is prohibited.



www.forjas-salvador.com

15 Cleaning

15.1 Cleaning fireplace insert, fuel gas flues

Fireplace insert & fuel gas flues (if present) must be cleaned at least 1 x per year in order to guarantee economic and trouble-free operation. Ceramic and metal fuel gas flues are cleaned via the cleaning openings provided for this purpose. The necessary work should be carried out by the manufacturer of the system or an appropriate specialist company. For this purpose the conclusion of a maintenance contract is recommended.

The chimney must likewise be regularly cleaned by the district master chimney sweeper. The latter will inform you of the necessary intervals.

15.2 Removing ashes

- On a regular basis and in good time (at least 1 x per week) remove the ashes from the firebox.
 - If the firebox is not regularly cleaned of ash then there is a danger that the combustion air openings become blocked and the appliance suffers damage.

To remove the ashes, proceed as follows:

NOTICE

Please note that when removing the ashes, embers could be in the firebox. Remove ashes only when the fireplace insert is in a cold state.

- 1) Open the door.
- 2) Remove ashes with a shovel and brush or with an ash vacuum cleaner.

15.3 Cleaning the washers on the door

- 1) The fireplace insert may only be cleaned when cold.
- 2) Before cleaning the glass, the fireplace seat and floor covering must be covered.
- 3) Spray window with glass cleaner and leave it for a moment to take effect.
 - ⇒ We recommend cleaning the glass with our Austroflamm glass cleaner or a commercially available window cleaner.
- 4) Rub off dissolved dirt with absorbent cloths or household paper.
- 5) Prevent door- or window seals from coming into contact with water or cleaner, since these will otherwise harden and in doing so will no longer function properly. Only intact seals ensure that your fireplace insert functions flawlessly.

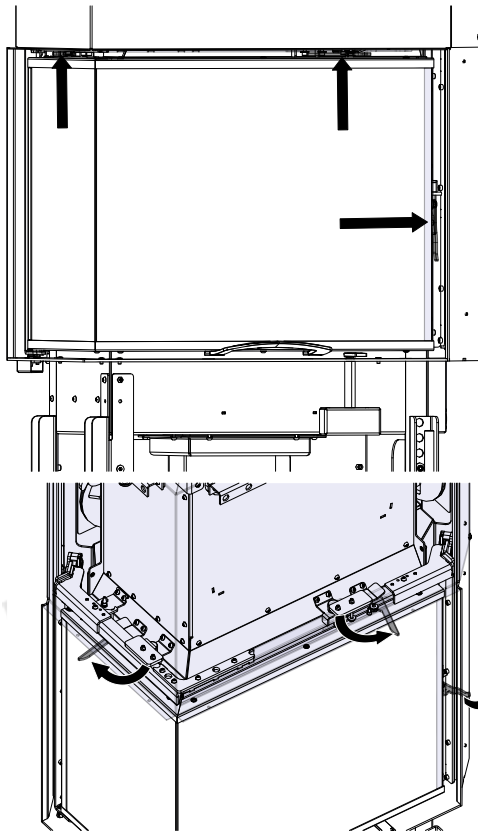

Fig. 82: Opening door lift

- 6) Open door lift.
- 7) Set the pivoting part to the rabbet and undo the door locks.

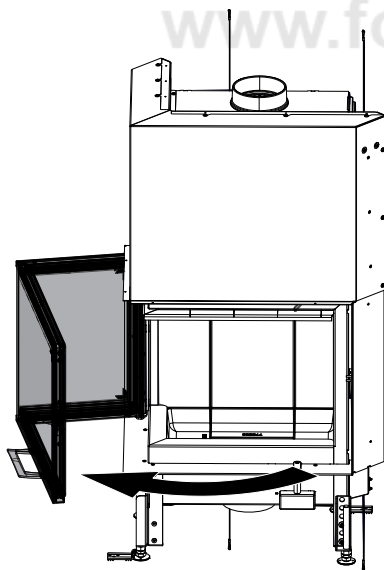

Fig. 83: Opening the door

- 8) Open the door approx. 80° so that the trunnion pin of the pivoting part is in front of the door frame.

- 9) Clean glass with glass cleaner.
- 10) After completing the cleaning, swing the door shut until it is flush.
- 11) Then gently lift and press to ensure that the hook engages correctly.
- 12) Only close completely with normal force once the locking hook is engaged.

16 Help

Problem	Cause	Solution
The glass window is sooty	Inadequate chimney draft or possibly too high	from time to time (depending on use) the window must be cleaned with glass cleaner Clarification with chimney sweeper (poss extend chimney/measure draft)
	incorrect operation of the air regulator	It is imperative that the air regulator is operated in accordance with the instructions (if secondary air is closed too far, the glass pane will become sooty very quickly)
	excessively large pieces of log log too damp	Comply with quantity and size according to the instructions
	Operating temperature has not been reached	Use more fuel, dry wood (< 15 % residual moisture), pay attention to air regulation
The chimney is too short	The chimney draft is insufficient	Ask your chimney sweep to carry out a draft measurement
	Exhaust ducts and combustion chamber sooted up	Use more fuel, dry wood (< 15 % residual moisture), pay attention to air regulation
The fireplace insert emits a strong odour and smokes externally	Stove-enamelling phase of the varnish	During the first heating cycles, the varnish hardens and smells in the process
	The fireplace insert surface is dusty/soiled	Keep the surfaces of the fireplace insert clean Keep the floor area clean around the fireplace insert
Flue gas escapes when stoking up and during the heating phase	Chimney draft too low or too strong, flue pipe connection leaky	Check connection points and if necessary reseal Check chimney draft
	Door opened before combusted down to embers	Only stoke up when only embers are present (no more visible flames)
The fire is too weak and/or goes out	Air regulator closed (-)	Air regulator open (+)
	Wood too damp	Are you using dry wood (< 15 % residual moisture)?
	External temperature too high (>15 °C)	
The room is not warm enough	Convection air grille closed	Open convection air grille
	Chimney draft too high	Clarification with chimney sweeper (poss shorten chimney/measure draft)
The fire burns down too quickly and uncontrollably	Air regulator open (+)	Throttle combustion air supply after the operating temperature has been reached in the firebox (+ / -)
	Seals worn	Check whether the seals on the inside of the door are continuous and in working order, if necessary replace
	Firebox door not closed properly	Close the firebox door
	Chimney draft too high	Clarification with chimney sweeper (poss shorten chimney/measure draft)



Problem	Cause	Solution
Ceramic windows become sooty very quickly	Unsuitable wood used	Use dry unrefined wood. See information about this in the Fuel section
	Operating temperature not reached	Bring fireplace insert to the operating temperature
		Sooting up of the window after 8- 10 hours of fires is normal
	Chimney draft too low	Contact chimney sweep

16.1 Firebox lining

The lining of your fireplace insert consists of Keramott, a high-quality material with special combustion properties and an attractive appearance. During or after operation this lining may have superficial hair-line cracks, which do not however affect functioning. Replacement of such parts is not required!

16.2 What to do in the event of a chimney fire

If fuel used is incorrect or too moist, then due to deposits in the chimney this may lead to a chimney fire.

- 1) Call the fire department and the district master chimney sweep!
- 2) Close the combustion air.
- 3) Enable access to the cleaning openings (e.g. basement and attic).
- 4) Remove all flammable material from the chimney.
- 5) Inform your district master chimney sweeper before recommissioning your fireplace insert and have your chimney checked for any damage.

16.3 What to do in the event of faults

Should faults occur on the fireplace insert, your dealer will require the following details:

- Serial number and appliance model as per the nameplate
- Original invoice (date of sale)



17 Spare parts

To order spare parts, please contact your Austroflamm dealer.



www.forjas-salvador.com



18 Dismantling

For correct uninstallation and dismantling of the fireplace insert, contact your Austroflamm specialist dealer.



www.forjas-salvador.com

19 Disposal

NOTICE

To dispose of the fireplace insert properly, get in touch with the local (possibly municipal) waste disposal company.

NOTICE

We recommend that you remove those components of the fireplace insert which have been in contact with fire such as window, combustion chamber, grates, firebox lining (Keramott), ceramic, sensors and baffle plates and dispose of them in the household waste.

NOTICE

For correct uninstallation and dismantling of the fireplace insert,, contact your Austroflamm specialist dealer.

Electric and electronic components

Remove the electric and electronic components from the appliance by dismantling them. These components must not be disposed of via non-recyclable waste. Disposal should be carried out professionally via the electrical and electronic waste return system.

Keramott

Remove Keramott components. If present, fastening elements must be removed beforehand. Keramott components that have been in contact with fire or flue gas must be disposed of. Reuse or recycling is not possible. Local disposal options must be observed.

Steel sheet

Disassemble steel-sheet components of the appliance by mechanical crushing. If present, remove seals beforehand. Dispose of steel sheet parts as metal scrap. Local disposal options must be observed.

Cast iron

Disassemble cast-iron components of the appliance by unscrewing or flexing them from one another, or alternatively by mechanical crushing. If present, remove seals beforehand. Dispose of the cast-iron parts as metal scrap. Local disposal options must be observed.

Natural stone

Mechanically remove any natural stone present from the appliance and dispose of it as construction waste. Local disposal options must be observed.

Fittings etc. (for water-carrying appliances)

Disassemble the components for carrying water by unscrewing and removing them and dispose of them as metal scrap. Local disposal options must be observed.

Seals (glass fibre)

Mechanically remove the seals from the appliance. These components must not be disposed of via non-recyclable waste.as glass fibre waste cannot be destroyed through burning. Dispose of seals as glass- and ceramic fibre waste (artificial mineral fibres (AMF)). Local disposal options must be observed.



Handles and decorative elements made of metal

If present, disassemble or remove handles and decorative elements made of metal and dispose of as metal scrap. Local disposal options must be observed.



FORJAS

SALVADOR

www.forjas-salvador.com

20 Warranty and guarantee

- 1) **Warranty statement:** For your AUSTROFLAMM fireplace insert, we guarantee the flawless performance of the body for six years, and of all other steel and cast iron components for two years from the date of first sale.

Steel and cast-iron parts that manifest material- and or processing defects during the guarantee period (warranty case) will be replaced for new parts provided that the warranty case has been asserted to the best of the holder's knowledge within the statutory warranty period. Functional problems with electronic accessories (e.g. Insert Control automatic air control) shall only justify a warranty claim for the particular accessory.

Our warranty only covers the free delivery of the new parts: work- and travel times are not recorded.

- 2) **Exceptions:** We do not provide a guarantee on wear parts (e.g. Keramott, seals and grate), surface coatings, varnish, glass and ceramics. In the case of such defects no warranty case has occurred .

When heating up, during operation and when cooling down, your fireplace insert may produce some noise (crackling, soft clicking). This is caused by the various materials expanding and contracting under the influence of temperature in your fireplace insert. Noise of this kind does not constitute a warranty claim and do not constitute a warranty claim.

The territorial scope of validity of our guarantee covers Austria and Germany. In all other countries, separate conditions of the importer apply to the respective country.

No warranty case occurs if your Austroflamm fireplace insert is not located within the territorial scope of validity, which does not change if it is transported or dispatched by Austroflamm."

- 3) **Requirements:** A warranty case shall only then be replaceable if your Austroflamm fireplace insert has been operated, maintained, installed and commissioned by a specialist authorized by Austroflamm, all in compliance with the user handbook. For the replaceability of the warranty case the start-up log must be received by Austroflamm within one month at the latest of the initial commissioning. In order to make a claim on the warranty, repairs to your fireplace insert must only be carried out by a service engineer authorized by Austroflamm.

The warranty claim is asserted with the invoice and serial number with the Austroflamm specialist dealer via whom the purchase was made. An unjustified warranty claim will be charged back to you.

- 4) **Guarantee:** This guarantee does not affect your statutory warranty rights towards us. Should your Austroflamm fireplace insert already be defective at the point of handover, you can always connect us within the framework of the statutory warrant regardless of whether there is a warranty claim or the guarantee is claimed.

21 Start up log

Operator / Customer	Dealer / Engineer
Name	Company
Street	Street
Town and postal code	Town and postal code
Telephone	Telephone
Email	Email

Fireplace insert	Working	Comments
Model		
Serial number		
Technology		
Visuals		
Accessories		

On-site conditions	
Type of chimney <input type="checkbox"/> brick <input type="checkbox"/> stainless steel <input type="checkbox"/> firebrick	Flue pipe diameter:
Chimney diameter:	Draft: Actual value: Target value: >12 Pa
Chimney height:	Outside temperature during draft measurement:
Controlled living space ventilation <input type="checkbox"/> yes <input type="checkbox"/> no	External air supply conduit <input type="checkbox"/> yes <input type="checkbox"/> no

Instructions for Operator / Customer		
Instructions for handling the appliance explained clearly and comprehensibly	Appliance test heated together with the customer	
Terms of the guarantee and warranty explained <input type="checkbox"/> glove <input type="checkbox"/> user instructions handed over	Cleaning and maintenance interval explained	

The customer confirms that the fireplace insert has been handed over in a fully functional state and free of defects.

Place, date

Signature Operator / Customer

Signature Technician



www.forjas-salvador.com



www.forjas-salvador.com

Endkontrolle

Final inspection
Controllo finale
Contrôle final

Technische Funktion
technical function / funzione tecnica / fonction technique

Lackierung / paint / vernice / peinture

Sauberkeit / cleanliness / pulizia / propreté

Vollständigkeit / completeness / completo / complet

Geprüft von / checked by / controlled da / contrôlé par

Datum / date / data / date



Typenschild (Duplikat)
Type plate (duplicate)
Targhetta (duplicato)
Plaque signalétique (duplicata)

AUSTROFLAMM GMBH
Austroflamm-Platz 1
A- 4631 Krenglbach

Tel: +43 (0) 7249 / 46 443
www.austroflamm.com
info@austroflamm.com

AUSTROFLAMM