



www.forjas-salvador.com

45X51-KII



AUSTROFLAMM



WI



OR

m

Maßstab 1:20

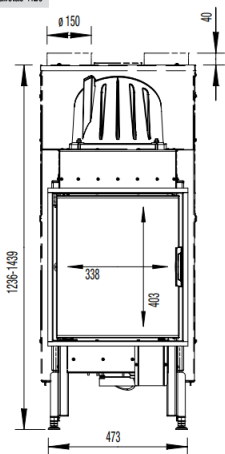

Maßstab 1:10

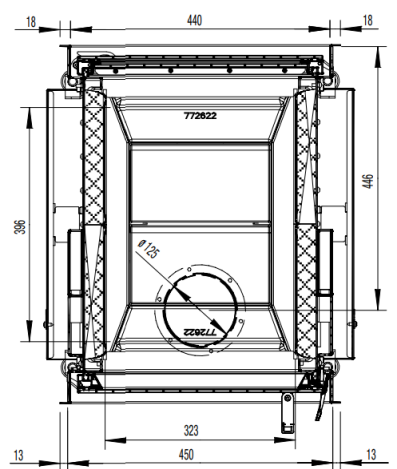
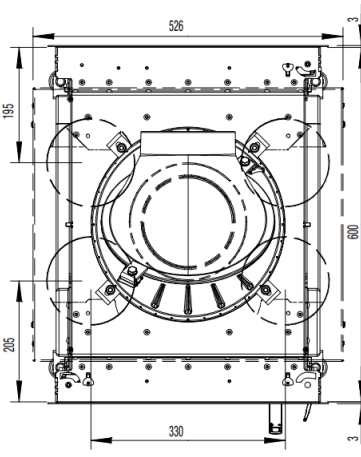
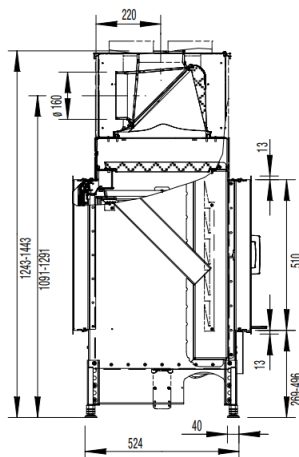

www.austroflamm.com

Dimensions and weight	
Height from [mm]	1241
Height to [mm]	1441
Width (body installation dimension) [mm]	456
Depth [mm]	600
Door frame height [mm]	510
Door frame width [mm]	456
Weight, basic appliance [kg]	124
Weight, HMS [kg]	-
Combustion chamber height [mm]	450
Combustion chamber width [mm]	324
Combustion chamber depth [mm]	430
Flue pipe outlet, diameter [mm]	180
dR Distance rear [mm]	1100
dS1 Distance left [mm]	0
dS2 Distance right [mm]	0
dP Radiation front [mm]	1100
dF Radiation to the floor [mm]	-
dB Distance bottom [mm]	0
dL 1 Radiation left [mm]	-
dL 2 Radiation right [mm]	-
dC Distance above [mm]	750
Safety distance to insulation, rear [mm]	-
Safety distance to insulation, right [mm]	60
Safety distance to insulation, floor [mm]	0
Insulation material thickness to installation base [mm]	20
Insulation material thickness to ceiling [mm]	-
Minimum distance from non-flammable materials [mm]	50
Insulation material, left [mm]	130
Insulation material thickness, right [mm]	130
Insulation material, rear [mm]	-
Cross-section, convection outlet [cm ²]	700
Cross-section, convection inlet [cm ²]	700
Max. amount of firewood fuel to be deposited [kg]	1.36
Output	
Nominal heat efficiency [kW]	6.0
Minimum heat output [kW]	NPD
Maximum heat output [kW]	6.0
Energy efficiency class	A
Circulating air cross-section with metal heat recovery surface [cm ²]	1300
Circulating air cross-section without metal heat recovery surface [cm ²]	700
Combustion air requirement [m ³ /h]	23.04
Minimum fuel throughput [kg/h]	-
Maximum fuel throughput [kg/h]	1.6
Outside air connection diameter [Ø mm]	125
Data for the chimney sweep	
Exhaust gas mass flow [g/s]	5.52
Flue gas temperature [°C]	292
Minimum delivery pressure at nominal heat output [Pa]	12

Equipment	
Hinged door	Yes
Sliding door	No
Double pane	Yes
Pane curvature	Flat
Opening mechanism	Folding
Balanced flue - DiBt (German Institute for Structural Engineering)	Yes
Heat Memory System	-
Hypocaust in compliance with technical regulations	Yes



www.forjas-salvador.com