



www.forjas-salvador.com

55X55X51-K-3.0



AUSTROFLAMM



www.forjas-salvador.com



www.austroflamm.com

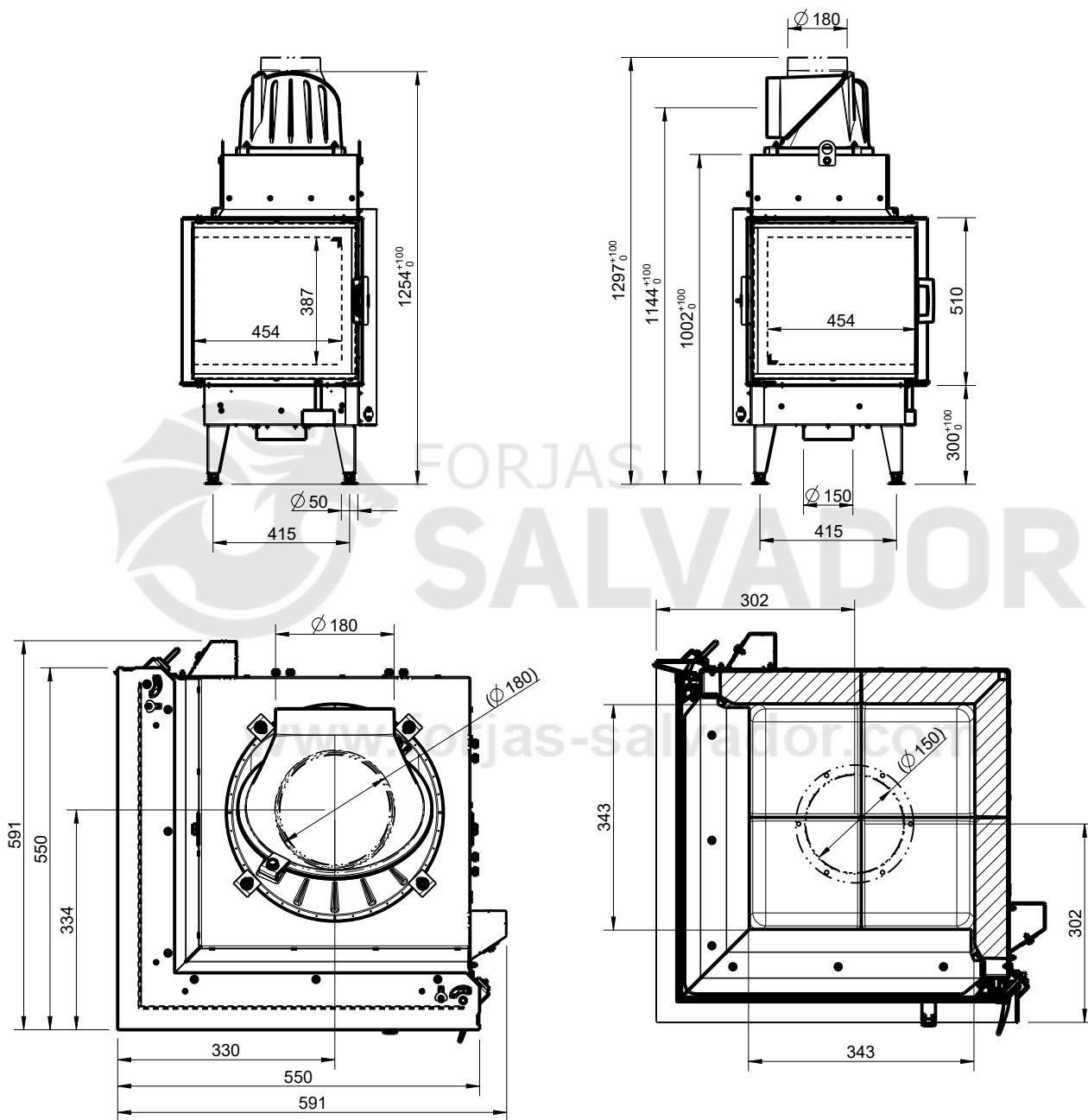

1:10

DIMENSIONS AND WEIGHTS

Height [mm]	1297-1397
Width [mm]	591
Depth [mm]	591
Weight [kg]	105
Width (body installation dimension) [mm]	550
Door frame, height [mm]	510
Flue pipe outlet, diameter [mm]	180
Insulation layer thicknesses at installation base [mm] (Promasil 950 KS)	0
Insulation layer thicknesses, lateral / rear [mm] (Promasil 950 KS)	60
Insulation layer thicknesses at ceiling [mm] (Promasil 950 KS)	60
Ceramic flues - max. length [mm]	4

HEAT OUTPUT

Nominal heat efficiency [kW] lt. EN test EN 13229	11,3
Heat output, minimum [kW] / Heat output, maximum [kW]	6-16
Energy efficiency category	A
Circulating air cross-section without / with metal secondary heating surface [cm ²]	700/1000

FEATURES

Hinged doors	yes
Double pane	x

DATA FOR THE CHIMNEY SWEEP

Flue gas mass flow [g/s]	11.5
Flue gas temperature [°C]	330
Minimum delivery pressure at nominal heat output [Pa]	14