



www.forjas-salvador.com

LUCY COOK



AUSTROFLAMM



FORJAS
SALVADOR

www.forjas-salvador.com



www.austroflamm.com



www.forjas-salvador.com



www.forjas-salvador.com

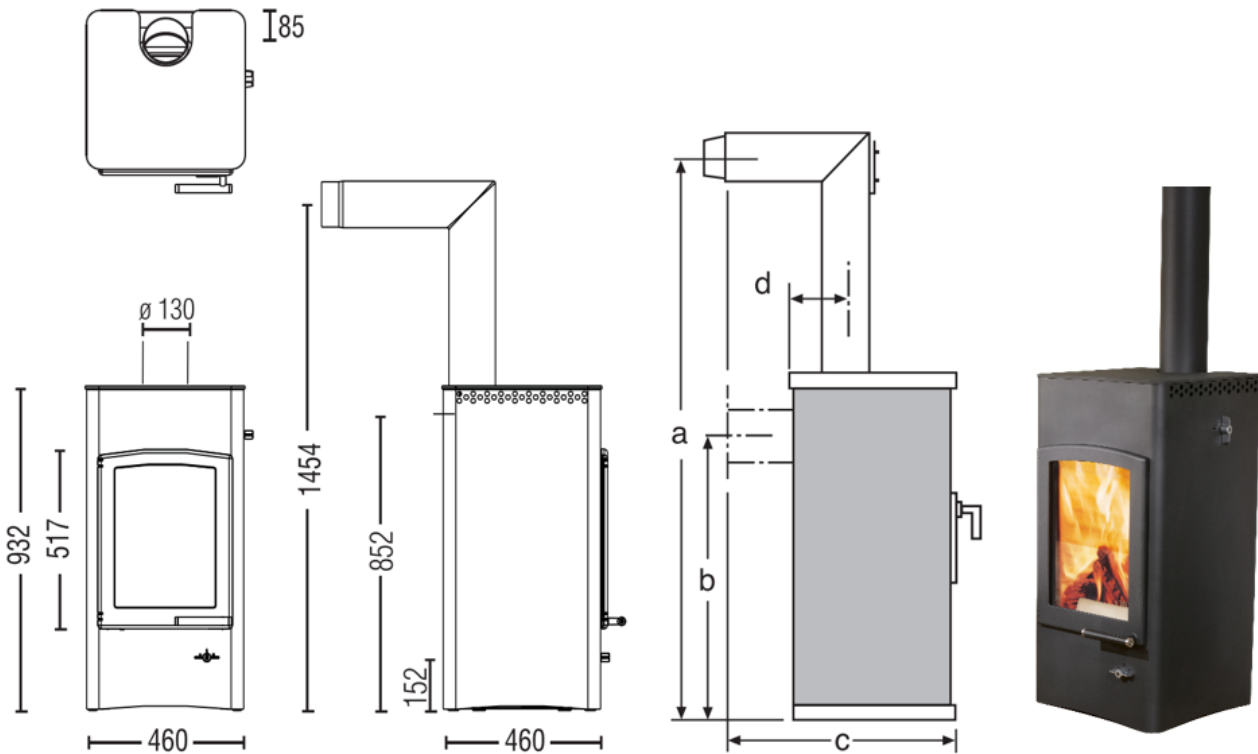

DIMENSIONS AND WEIGHTS

Steel casing (STM) h x w x d [mm]	932 / 460 / 460
Ceramic casing (KMG) h x w x d [mm]	-
Soapstone casing (SPM) h x w x d [mm]	-
Firebox h x w x d [mm]	471 x 302 x 239
Hotplate w x d [mm]	460 x 460
Weight STM [kg]	150
Flue pipe outlet [mm]	130
Flue pipe connection, middle [mm]	852
Dimensions a, b, c, d [mm]	1454 / 852 / 741 / 85
Safety distances to combustible materials front / side / rear* [mm]	800 / 100 / 100 / 200*
*if the connecting pipe is not insulated	

HEAT OUTPUT

Nominal heat output under EN 13240 [kW]	6
Min. / max. heat output [kW]	3.5 / 8
Space heating capacity (depending on the building insulation)[m³]	65 - 165
Energy efficiency category	A+

FITTINGS

XTRA heat storage technology	-
Heat Memory System (HMS)	-
Ash box	o
external air connection / balanced flue operation	rear

DATA FOR THE CHIMNEY SWEEP

Total flue gas flow, closed [g/s]	4.9
Flue gas temperature, closed [°C]	290
Minimum feed pressure at nominal heat efficiency, closed [Pa]	12
at 0.8 times nominal heat efficiency [Pa]	10